

Vogue

WALL UNIT

150 - 600 Tall 1 Door Assembly Guide

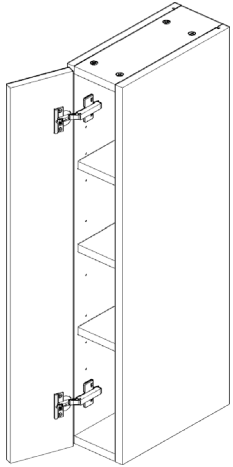

150 Tall

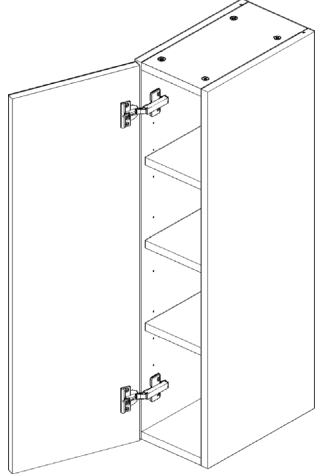

200 Tall

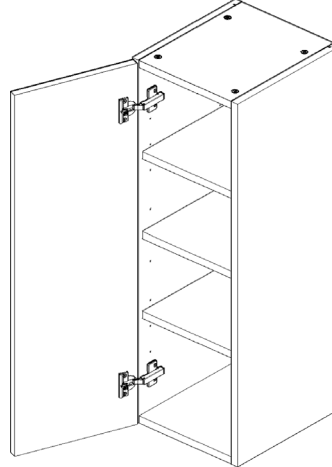

300 Tall

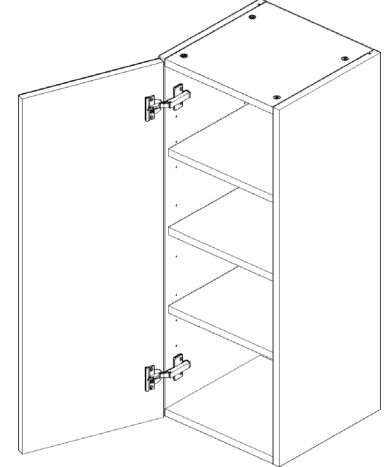

350 Tall

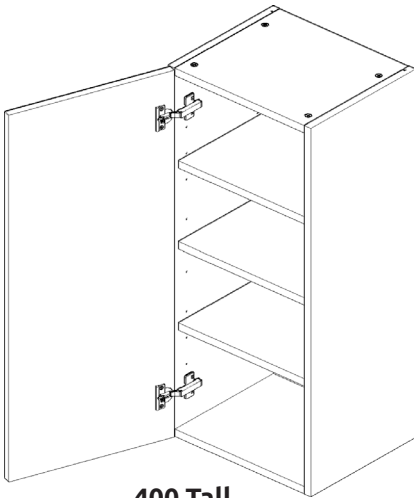

400 Tall

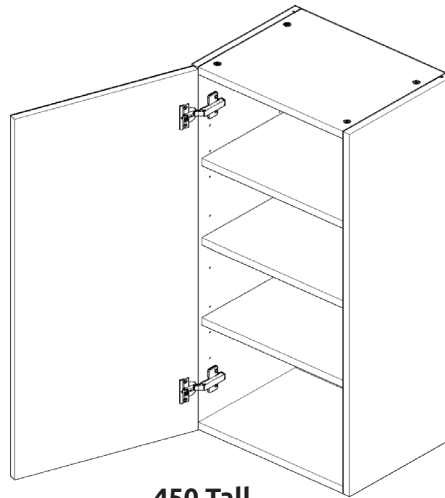

450 Tall

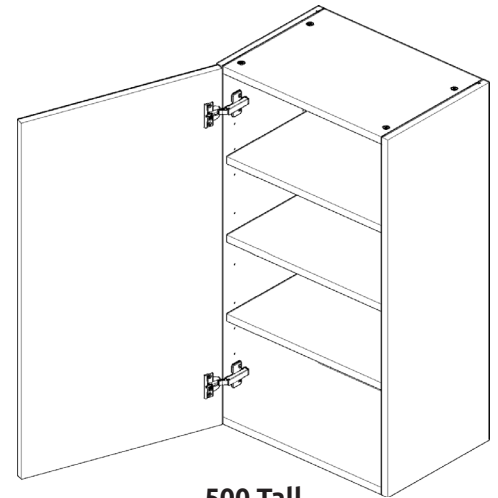

500 Tall

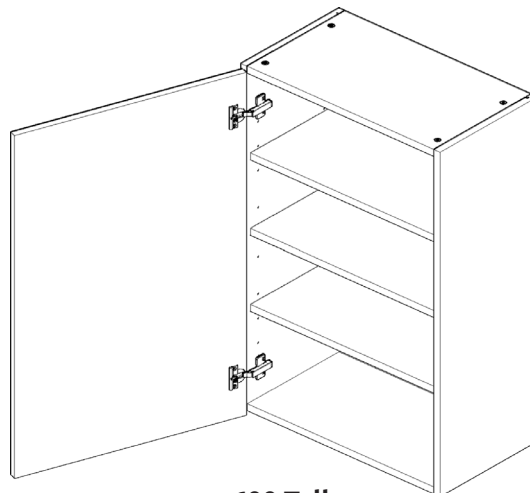

600 Tall

WALL UNIT

150 - 600 Tall 1 Door Assembly Guide

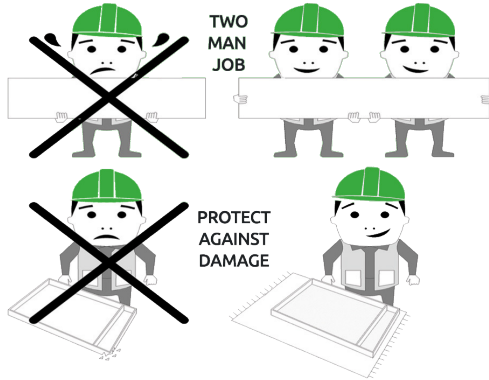

BEFORE YOU START

INSTALLATION SHOULD BE PERFORMED BY A COMPETENT PERSON ONLY.

THIS PRODUCT COULD BE DANGEROUS IF INCORRECTLY INSTALLED

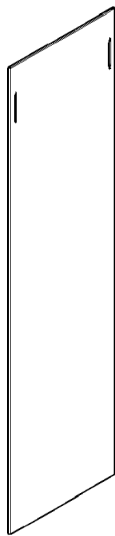

Panel A
x1 Back Panel



Panel B
x2 End Panel

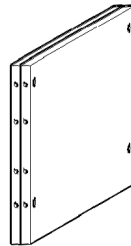

Panel C
x2 Base Panel

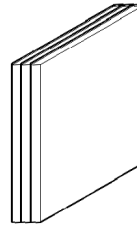

Loose Shelf
x3

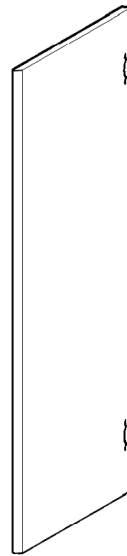

Frontal
(packed separately)
x1

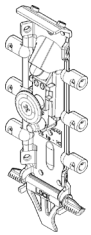

HANGING BRACKET
x2 Inc Screws

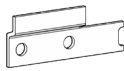

HANGING BRACKET PLATE
x2 (Screws NOT included)

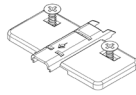

HINGE MOUNTING PLATE
x2 Inc Screws

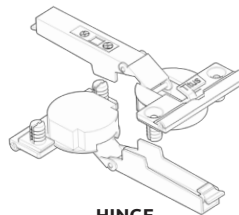

HINGE
x2 Inc Screws



CORNER GUSSET
x2

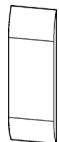

HANGING BRACKET COVER CAP
x2



(F) x8
Wooden Dowel

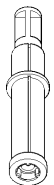

(G) x8
Cam Dowel (Expanding)



(H) x8
Cam Lock



(K) x2
30mm Screw

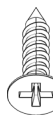

(L) x8
15mm Screw

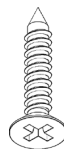

(S) x4
20mm Screw



(M) x2
Cover Cap

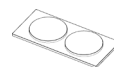

(N) x1
Door Buffer

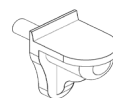

(Z) x12
Shelf Peg Plastic



(T) x10
Back Panel Support Clip

REQUIRED TOOLS



NOT to be used with CAM DOWEL & CAM LOCK



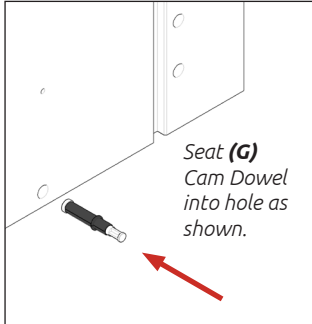

Step 1.
Seat dowel (F)
into holes in
both end panels (B)
as shown.

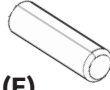

Step 2.
Seat cam dowel (G)
into holes in both end panels (B)
as shown.

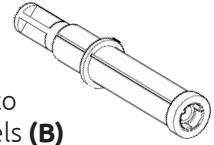

Step 3.
Attach panels x2 (C)
to panel (B), using cam
dowels (G) (in blue), and
also using dowels (F) (in
orange) in positions as
shown.

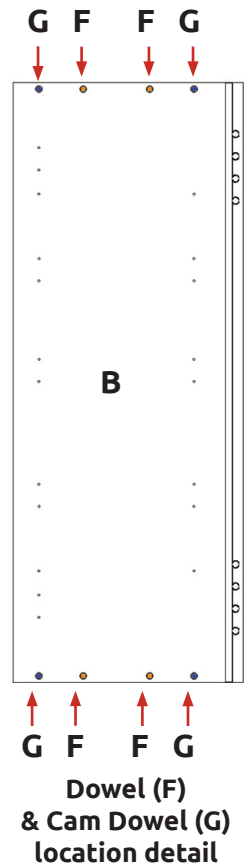
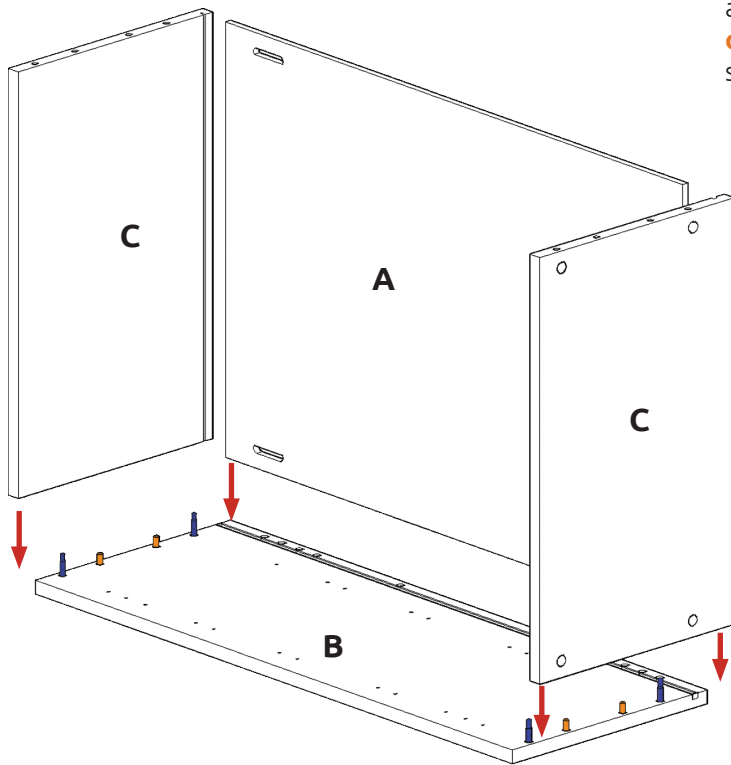

NB. All cam locks (H) are to be positioned facing the outside of the unit Carcase, for ease of tightening.

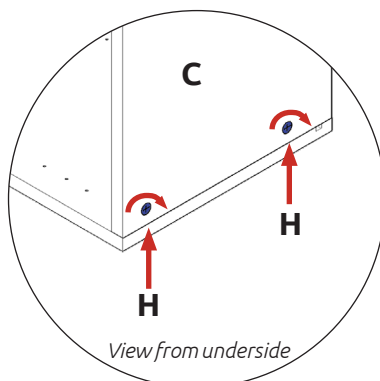
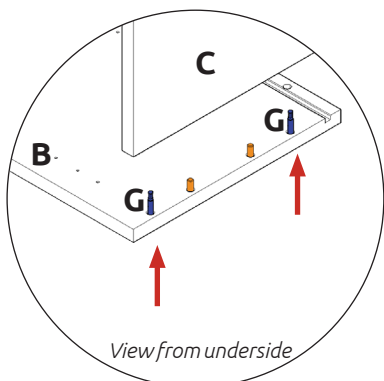

Do **not** use power tools with
cam dowel (G) or cam lock (H)

Step 5.
Insert cam lock (H).
Hand tighten all
cam locks (H), this
will expand the cam dowels
(G) and tighten the unit
together.



WALL UNIT

150 - 600 Tall 1 Door Assembly Guide

Step 6.

Seat dowel (F) into holes in both panels (B) as shown.

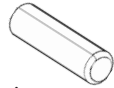

Step 7.

Seat cam dowel (G) into holes in both end panels (B) as shown.

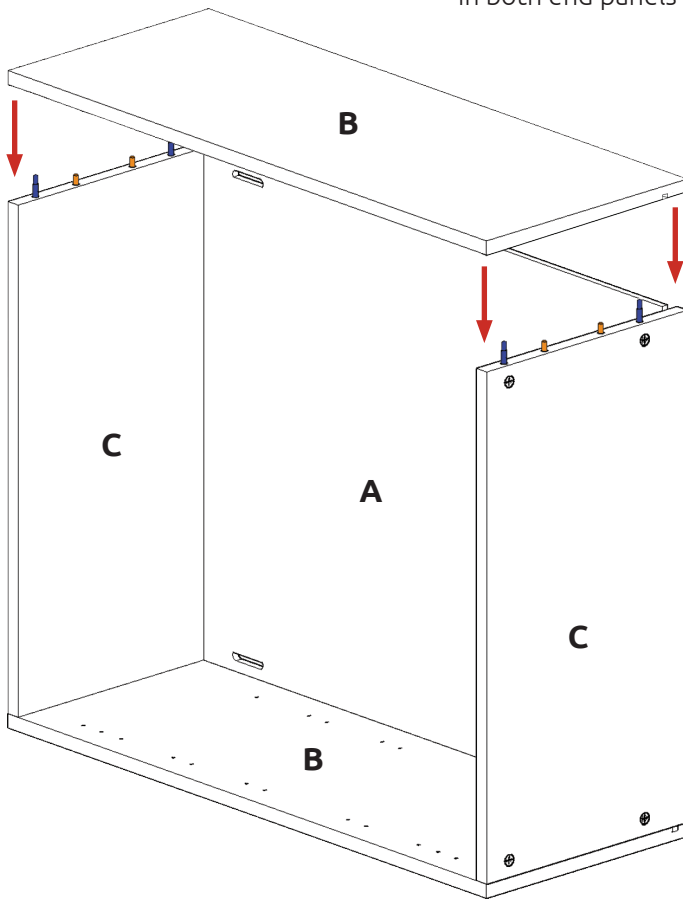
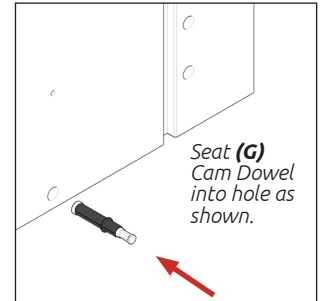
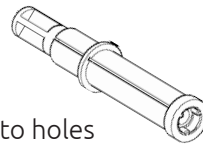

Step 8.

Attach panel (B) to panels (C) using cam dowels (G) (in blue) and also using dowels (F) (in orange) in positions as shown. Ensure panel (A) is seated into the groove of panel (B).

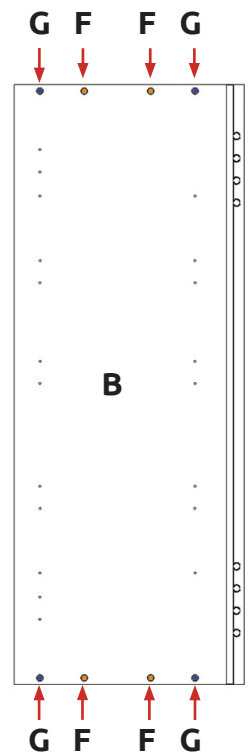

Dowel (F) & Cam Dowel (G) location detail



NB. All cam locks (H) are to be positioned facing the outside of the unit Carcase, for ease of tightening.

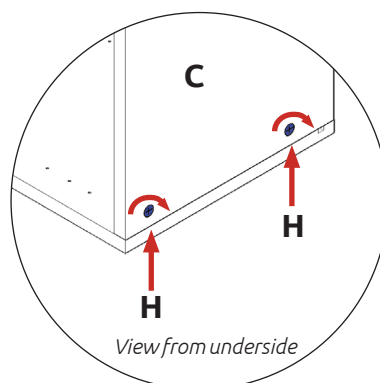
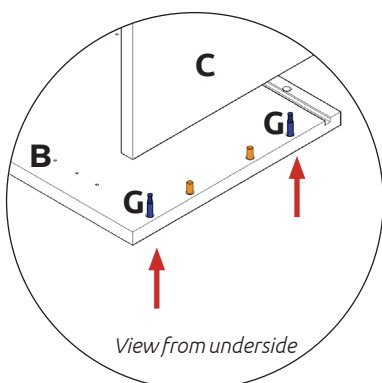

Do **not** use power tools with cam dowel (G) or cam lock (H)

Step 9.

Insert cam lock (H). Hand tighten all cam locks (H), this will expand the cam dowels (G) and tighten the unit together.



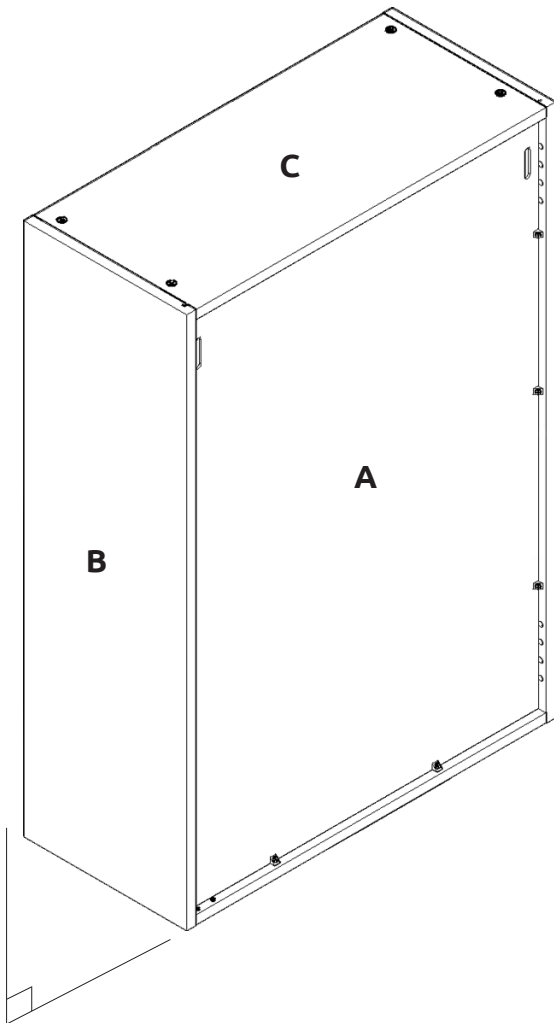

Step 10.
Ensure unit is square.

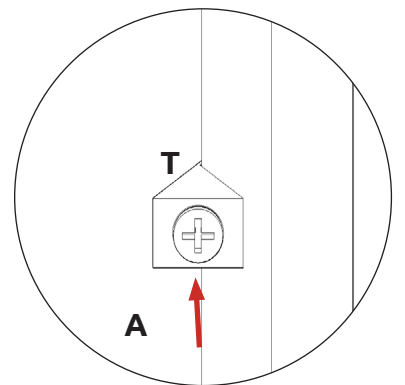
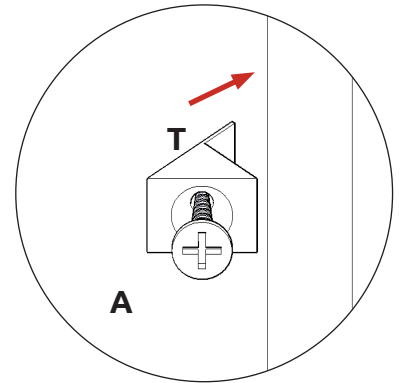

Step 11.

Slide the back panel clips (**T**) into the groove of both panels (**B**) & (**C**)s. The back panel clips (**T**) should be evenly spaced as shown and positioned to allow the hanging bracket and corner gussets to be fitted. Once in place, tighten screw.

Step 12.

Attach hinge mounting plates onto both end panels (**B**) in locations shown using screws (**L**) which are already positioned within the hinge plates.

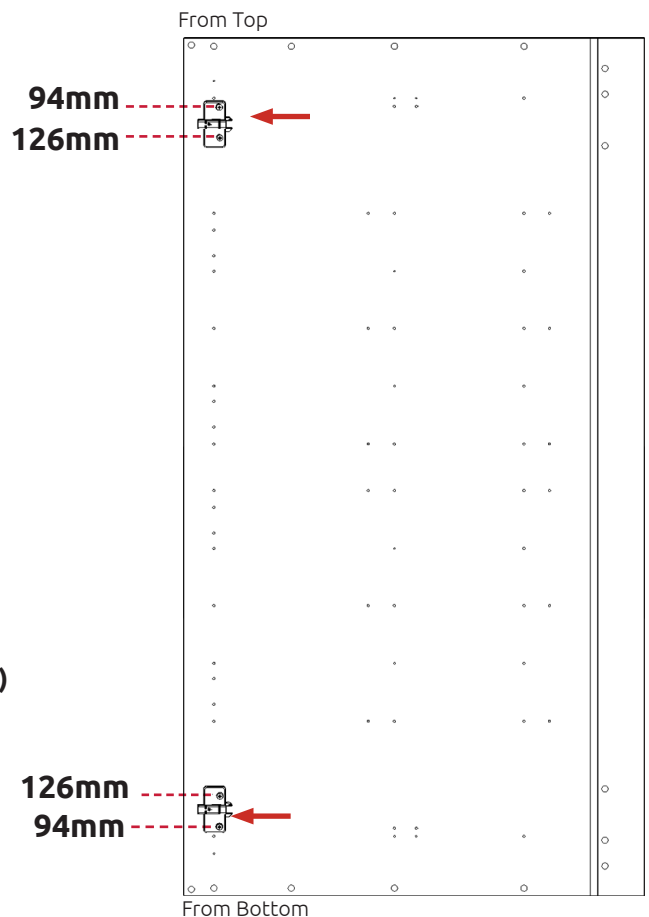

WALL UNIT

150 - 600 Tall 1 Door Assembly Guide



Screws for attaching to walls are not provided as these vary depending on materials, thickness and construction. Ensure appropriate fixings for wall construction are used.



Care to be taken. Hanging procedure is necessary for a safe installation.

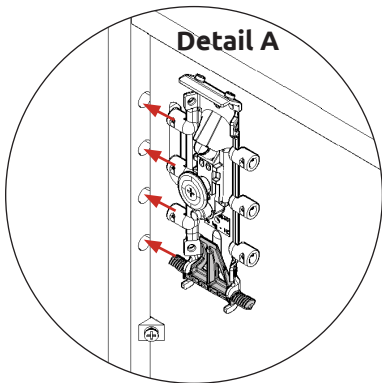

Step a

Insert hanging bracket into pre-drilled holes

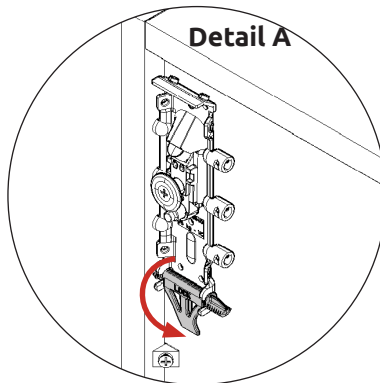

Step b

Rotate locking lever 180 degrees

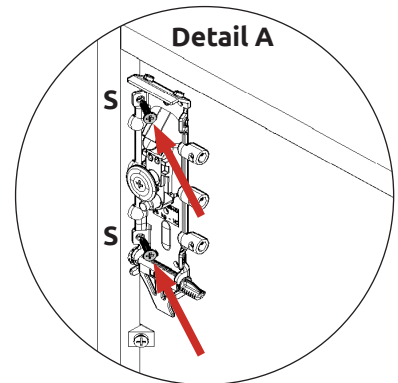

Step c

Secure with provided 2 x 20mm screws (S) per bracket

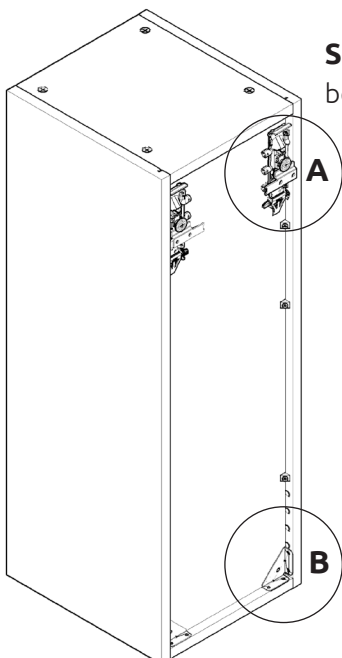

Step 13. Hanging Brackets steps a, b & c to be carried out on both sides as shown

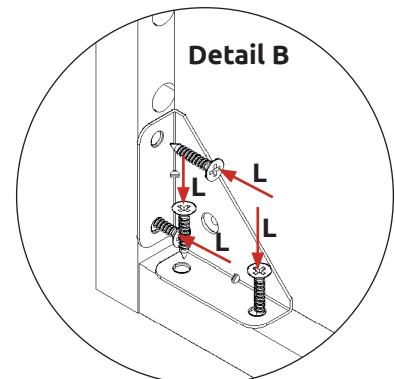

Step 14.

Secure corner gussets to the bottom left and right hand side of the wall unit using 4 x 15mm screws (L) per plate.

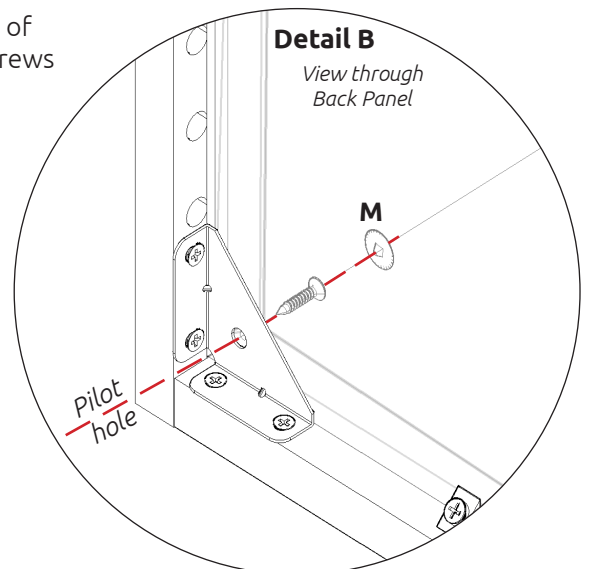

Step 15.

Drill a small pilot hole through the centre of the corner gussets, through the back of the unit. Use this hole at the end of the process to screw through and into the wall. Cover the screw heads using the cover caps (M) provided.

Screws for fixing to walls are not provided as these vary depending on your wall material and construction. Ensure appropriate fixings for wall constructions are used.

Step 16.

Measure appropriately and attach the 2 x hanging bracket plates onto the wall screwing through the provided holes into your wall.

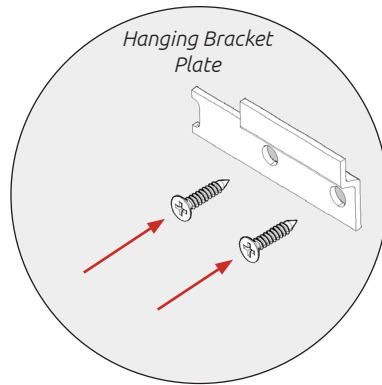

Step 17.

Hang the unit using the brackets to hook onto the plate as shown

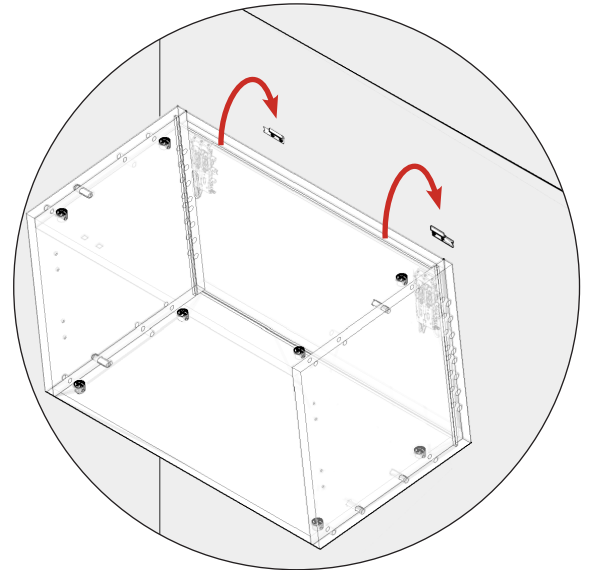

Step 18.

Using points a, b & c adjust the unit to suit.

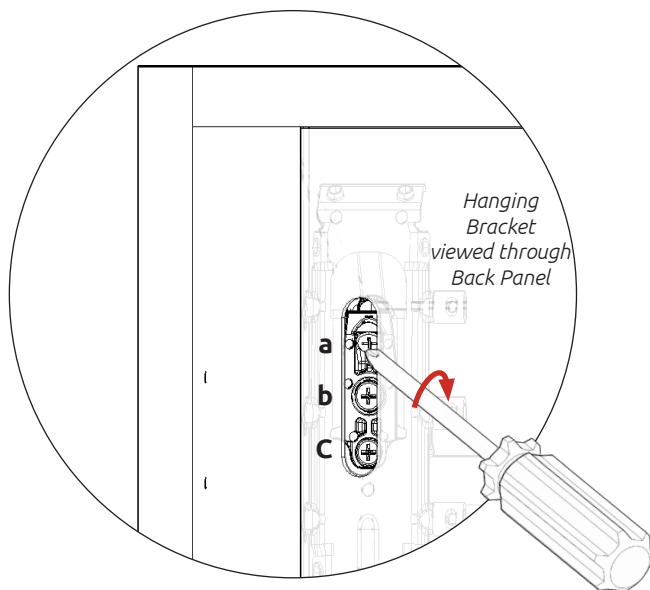

Step a.

Rotate the screw clockwise to move the unit up. Anti-clockwise for down.

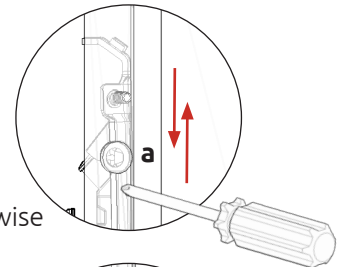

Step b.

Adjust the depth using centre screw.

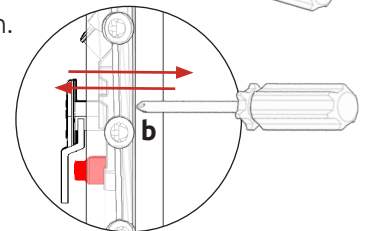

Step c.

Screw the red screw until it touches the plate to lock in position.

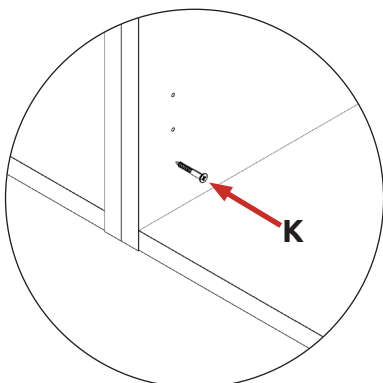
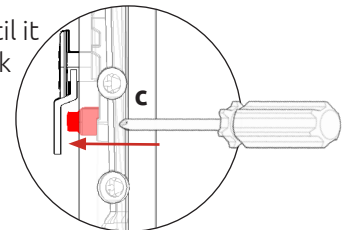

Step 19.

Screw into any side units using the provided 2 x 30mm screws (**K**) to secure the unit. Screw just to the rear of the hinge plate then place cover caps (**M**) on the head to conceal it.

WALL UNIT

150 - 600 Tall 1 Door Assembly Guide



Step 20.

Insert hinge in top & bottom holes as shown below.

Step 21.

Secure hinges by tightening 2 x screws with hinge dowels attached. These are already positioned within the hinges.

Step 22.

Attach the door to unit where required. To attach door, clip hinge onto hinge plate and click to secure.

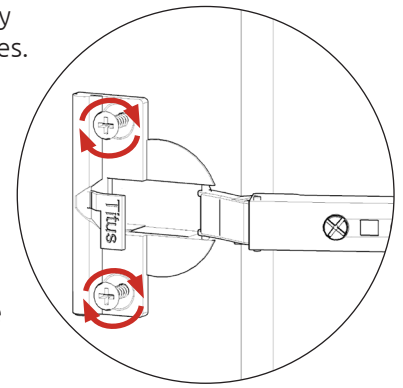

Step 23.

Adjust hinge to suit. As shown below.

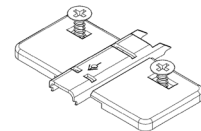
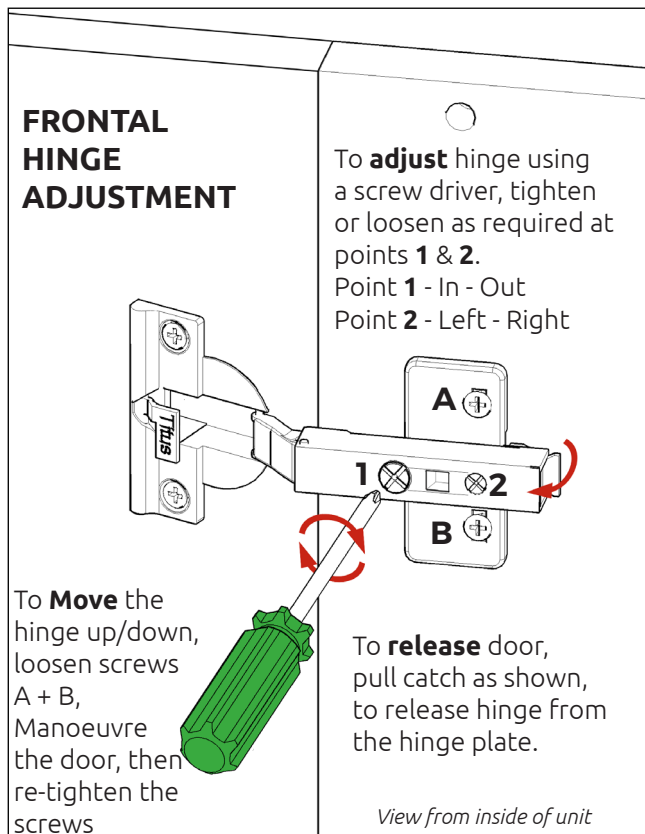

Hinge Plates

Step 24.

Fit cover caps to hinge. Adjust Soft close to suit.

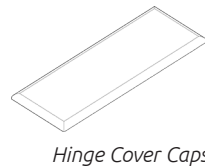

Hinge Cover Caps

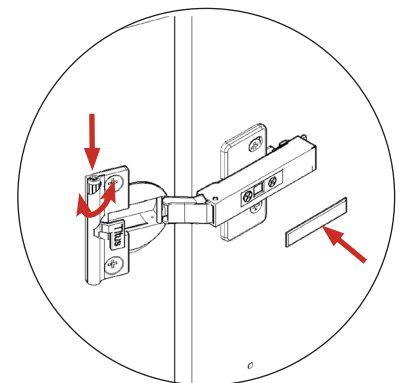

The top and bottom hinges **MUST** be adjusted to the **SAME STRENGTH.**