

BASE UNIT

150 1 Door

Assembly Guide

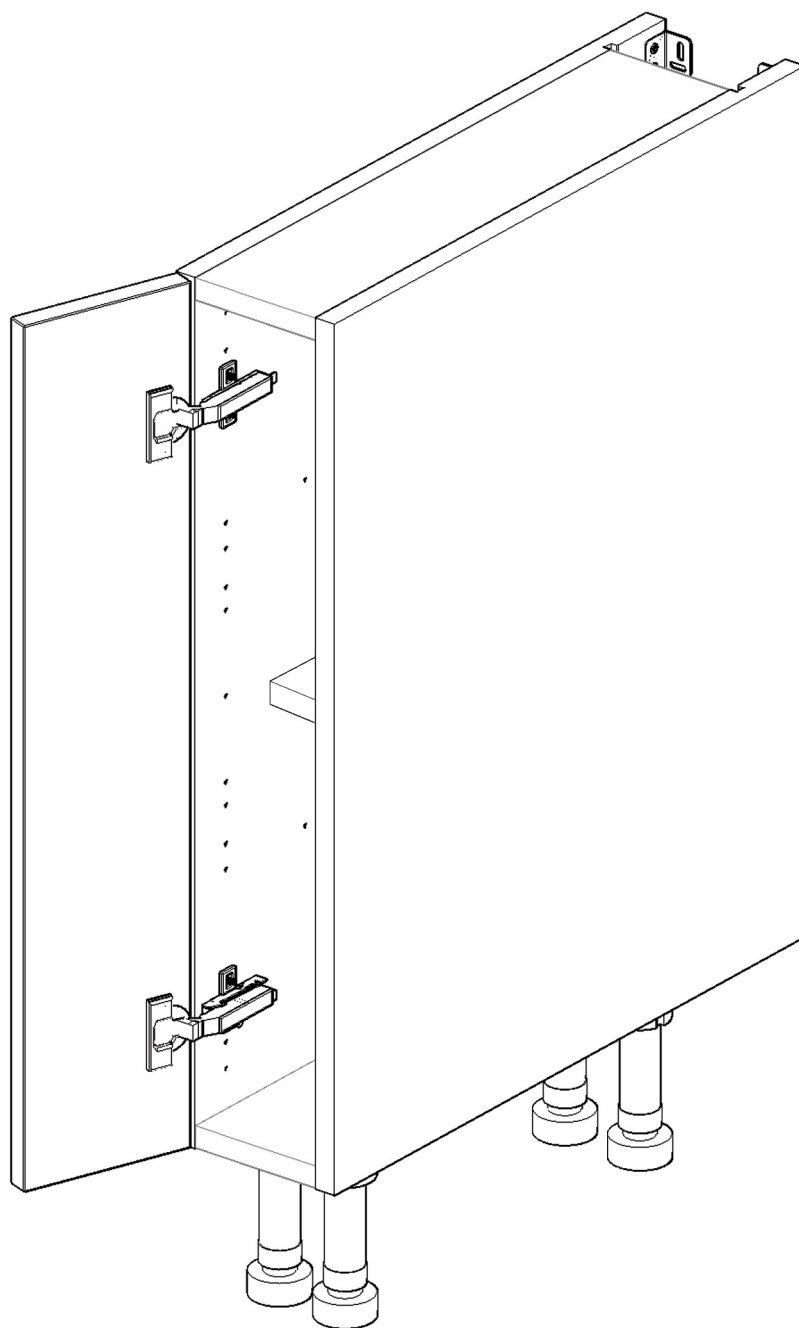

wren
KITCHENS

BASE UNIT

150 1 Door

Assembly Guide

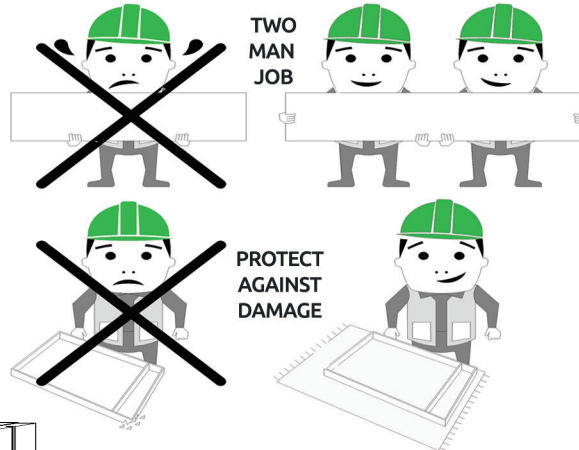

BEFORE YOU START

INSTALLATION SHOULD BE PERFORMED BY A COMPETENT PERSON ONLY.

THIS PRODUCT COULD BE DANGEROUS IF INCORRECTLY INSTALLED

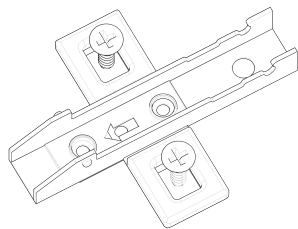
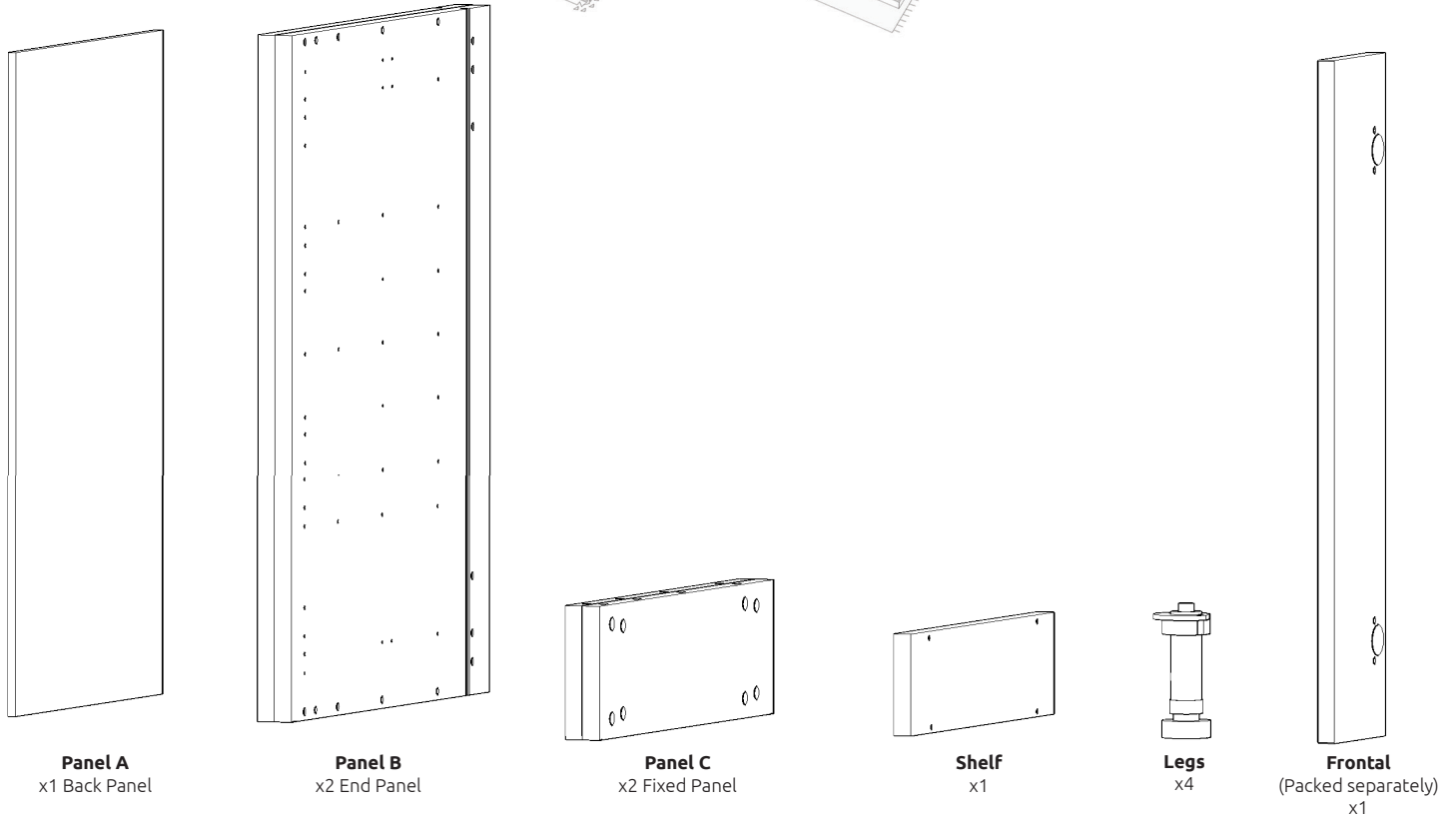

Hinge Mounting Plate
x2 Inc Screws

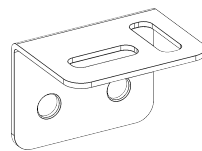

L Bracket
x2

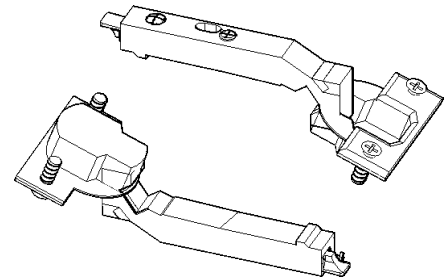

Hinge
x2 Inc Screws

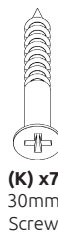
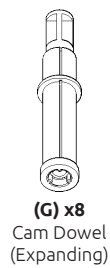
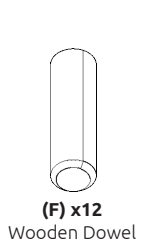

REQUIRED TOOLS

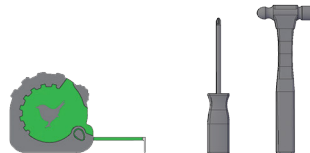

BASE UNIT

150 1 Door

Assembly Guide

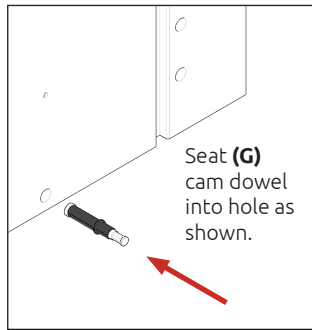

Step 1.
Seat dowel (F)
into holes in
both end panels (B)
as shown.

Step 2.
Seat cam dowel (G)
into holes in both end panels (B)
as shown.

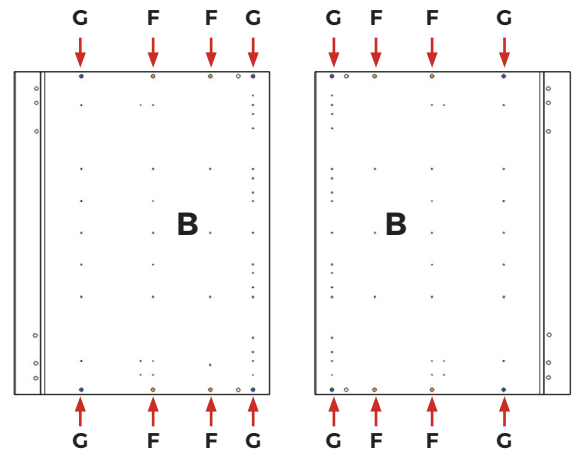
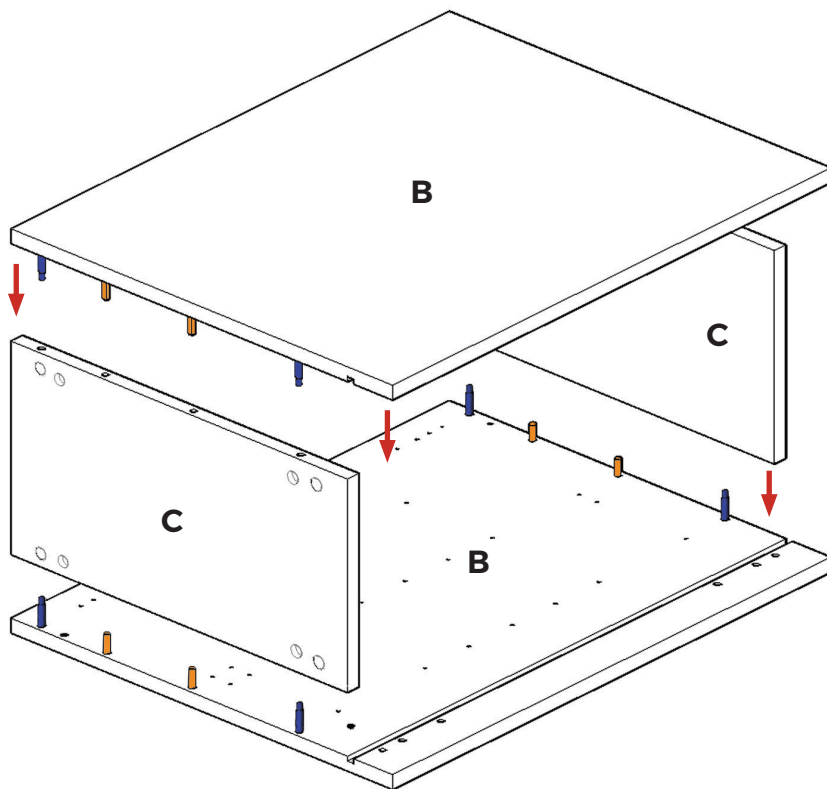

**Dowel (F)
& Cam Dowel (G)
location detail**

Step 3.
Carcass Construction
Attach panels (C) to panels
(B), using cam dowel (G) &
cam lock (H) (in blue), and
also using dowels (F) (in orange)
in positions as shown.

Do **not** use power tools with
cam dowel (G) or cam lock (H)

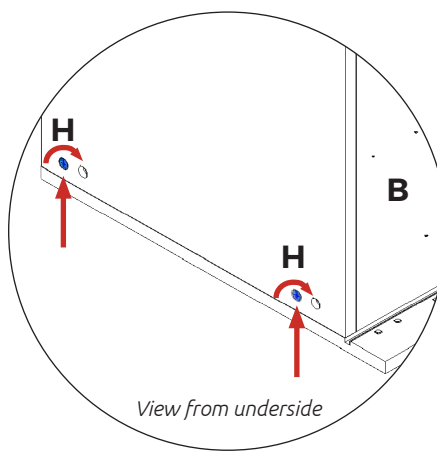
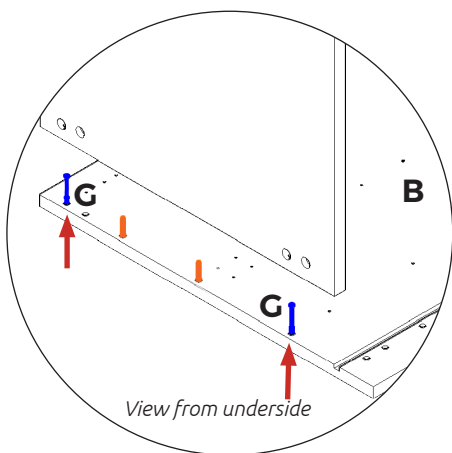

Step 4.
Join panels (C) to (B).
Insert cam lock (H).
Do **NOT** tighten until Step 6.



BASE UNIT

150 1 Door

Assembly Guide

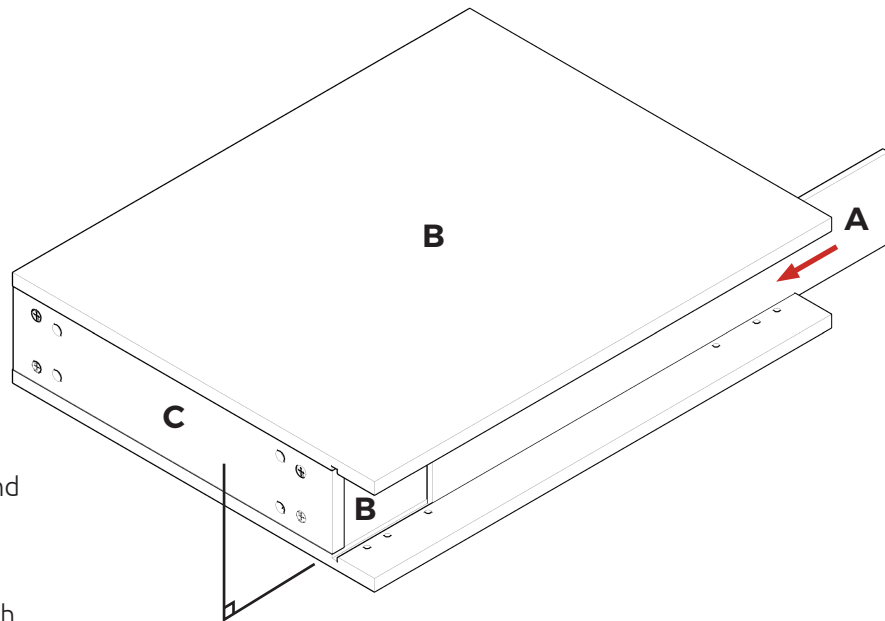

Step 5.

Slide back panel (A) into groove of end panels (B).

Once back panel (A) is in position, ensure the panel is flush & square with bottom of end panels (B).

Step 6.

Hand tighten all cam locks (H), this will expand cam dowels (G) and tighten the unit together.

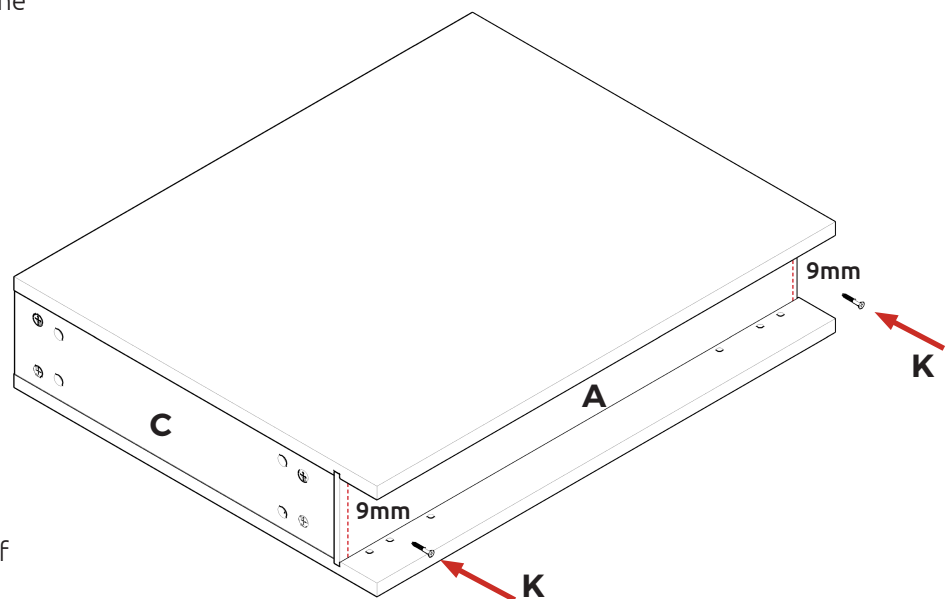

Step 7.

Ensure carcass is square. Secure back panel (A) with 2 x 30mm screws (K) equally spaced at the top & bottom of back panel (A) into both fixed panels (C), as shown.

Ensure you screw into the centres of the base panels (C) (9mm from the edge).

BASE UNIT

150 1 Door

Assembly Guide

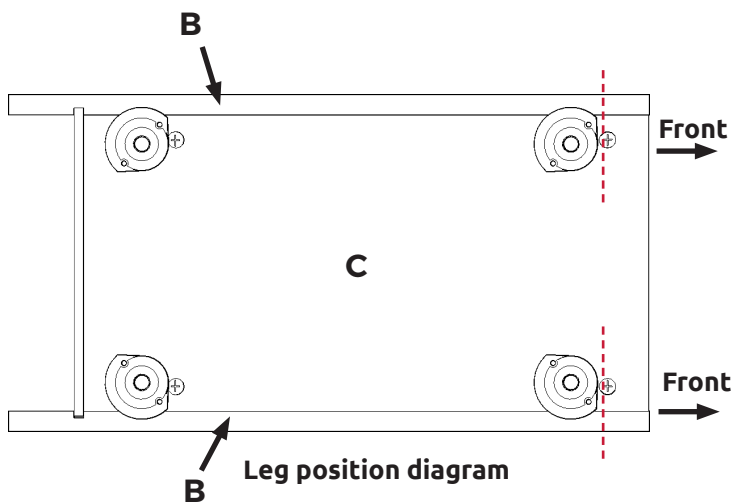

Step 8.
Secure each of the legs into place with 2 x 15mm screws (**L**) per leg.

Ensure legs are rotated as shown so that part of it is supporting the end panels (**B**).

Front legs should have flat edge to the front.

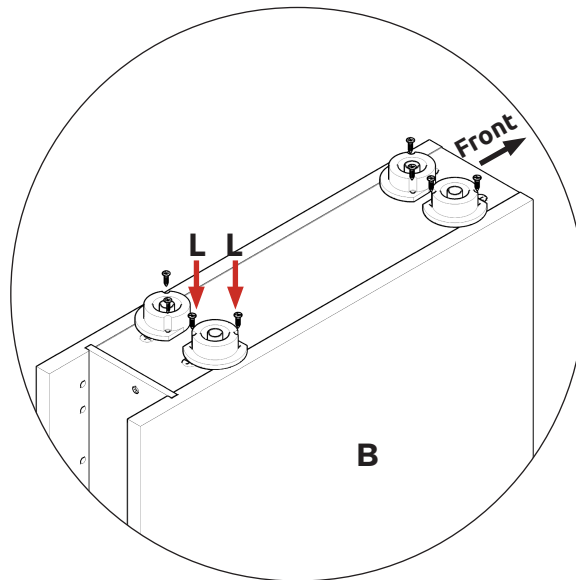

Step 9.
Lightly hit centre peg of leg base with hammer until flush.

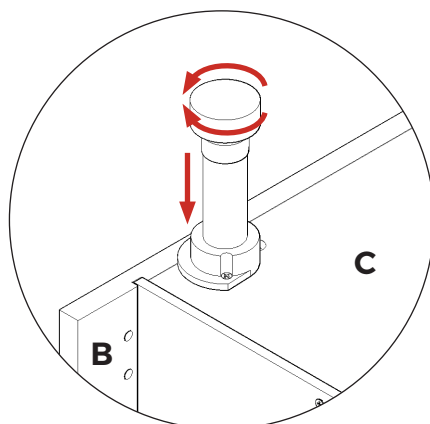
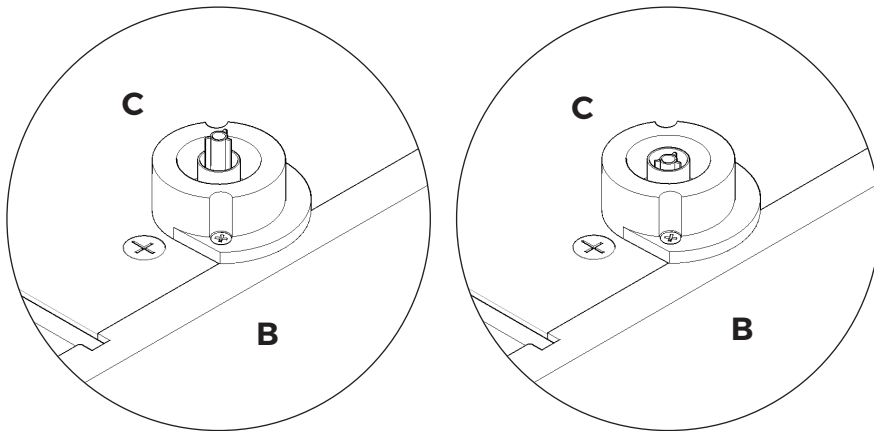

Step 10.
Push leg firmly down into leg base. Adjust legs to 155mm before turning carcass upright. Once in situ level accordingly.

BASE UNIT

150 1 Door

Assembly Guide

Step 11.

Attach Hinge Mounting Plate onto End Panel (B) as shown, using Screws which are already positioned within the Hinge Plates.

Hinge side to be mounted in accordance to customer kitchen plan.

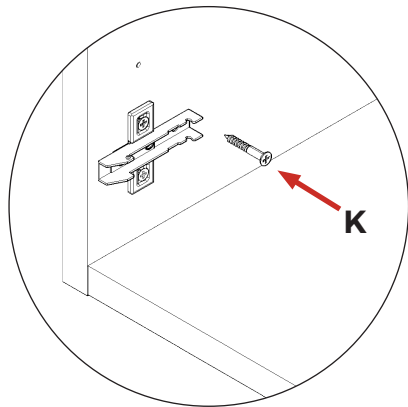
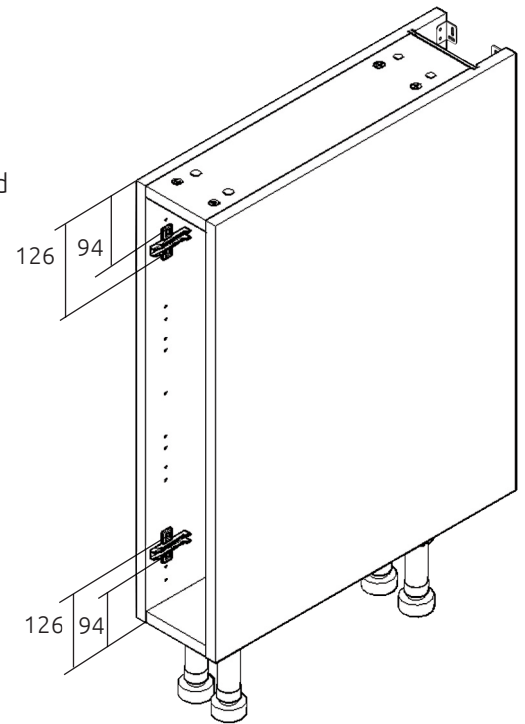

Securing to Adjacent Units
Screw into any side units using the 30mm screws (K) provided to secure to unit. Screw just to the rear of the hinge plate at the top and bottom of both sides of the unit, place a cover cap (M) on the head to conceal it.

L Brackets

Use 2 x 15mm screws (L) to secure each of the L brackets to the cabinets at either side. Then screw through into the wall as shown.

Screws for attaching to walls are not provided as these vary depending on your wall material and construction. Ensure appropriate fixings for wall construction are used.

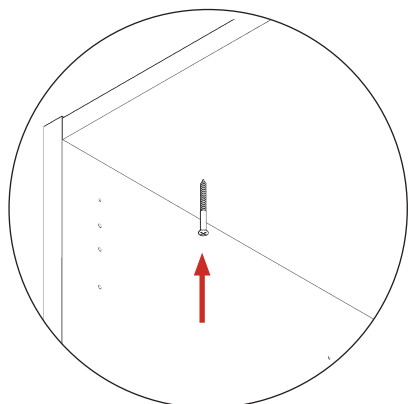
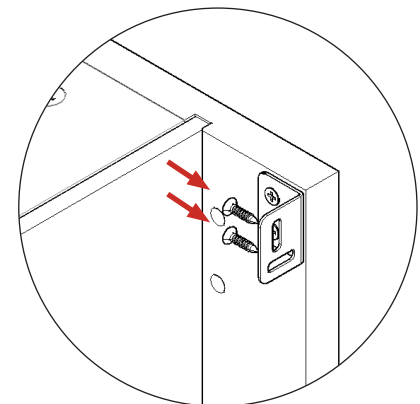
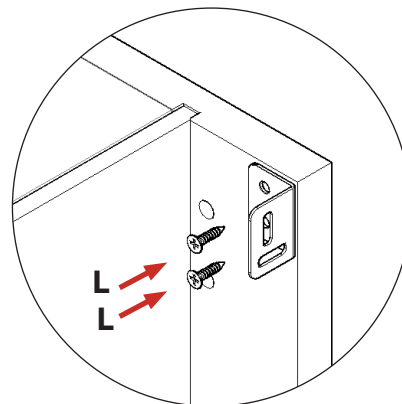

Worktop

Screw up through panel (C) into your worktop to secure it in place.

Screws for attaching to worktop are not supplied as these vary depending on worktop material and thickness. Ensure appropriate fixings for attaching worktop are used. Please refer to the specialist worktop supplier if these are required for solid surface worktops.

BASE UNIT

150 1 Door

Assembly Guide

Step 12.

Insert hinge in top & bottom holes as shown.

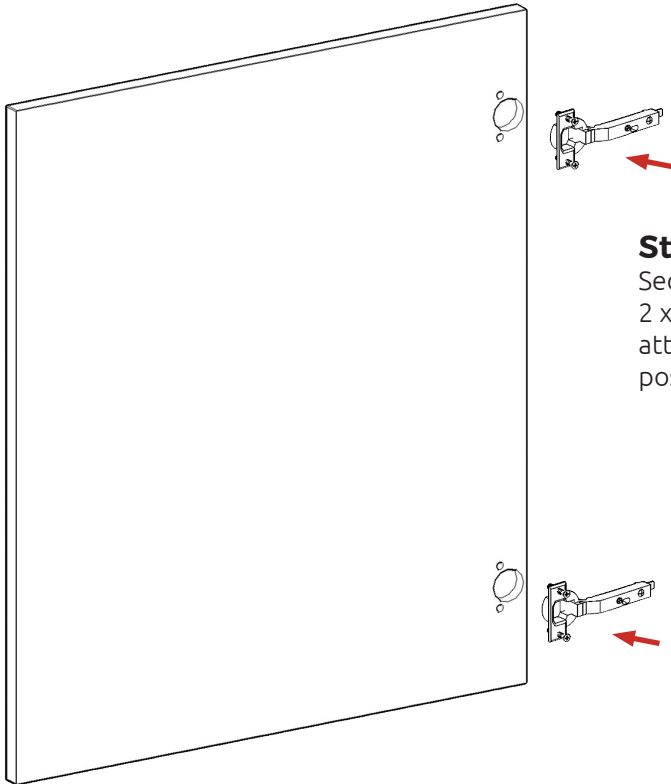
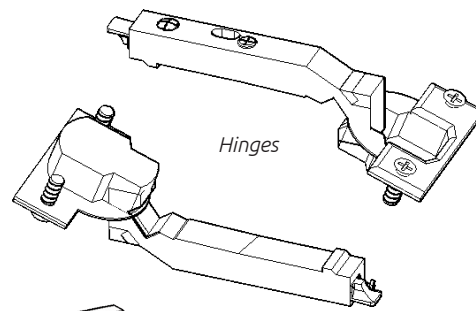

Step 13.

Secure hinges by tightening 2 x screws with hinge dowels attached. These are already positioned within the hinges.

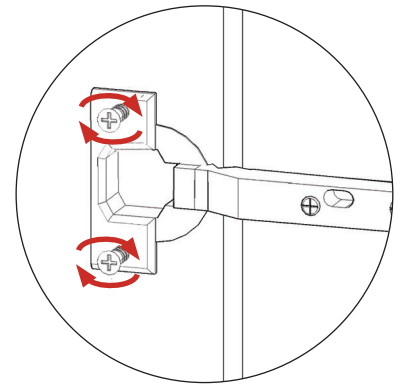

Step 14.

Attach the door to unit where required. Adjust hinges to suit. See below.

To **attach** door clip hinge onto hinge plate and click to secure.

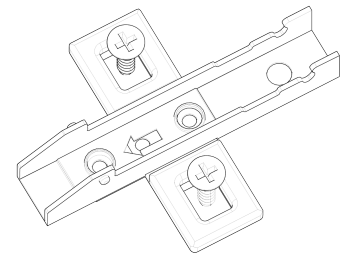

Hinge Plates

Step 15.

Adjust hinge to suit. As shown below.

Hinge Cover Caps

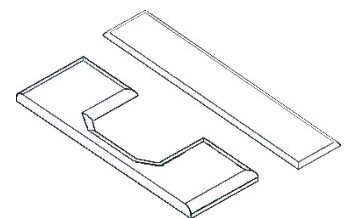

Step 16.

Fit cover caps to hinge.

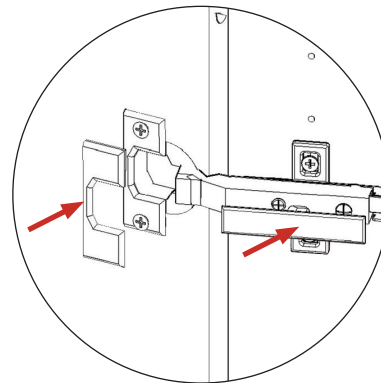

FRONTAL HINGE ADJUSTMENT

To **adjust** hinge using a screw driver, tighten or loosen as required at points **1** & **2**.

Point **1** - left - right

Point **2** - side - side

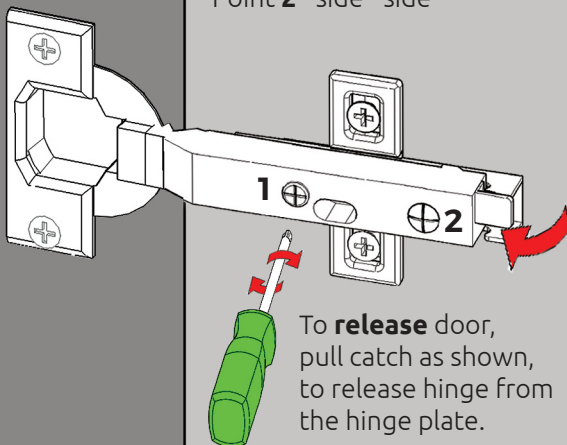

To **release** door, pull catch as shown, to release hinge from the hinge plate.

View from inside of Carcass

wren
KITCHENS