

TOWER UNIT

600 2 Door
Fridge/Freezer

Assembly Guide

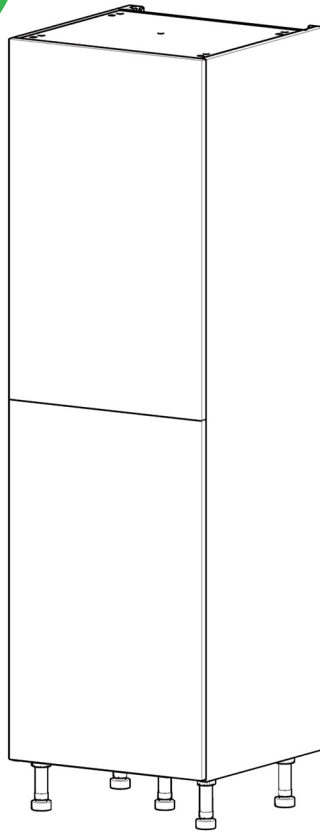

**2070 x 600
50/50**

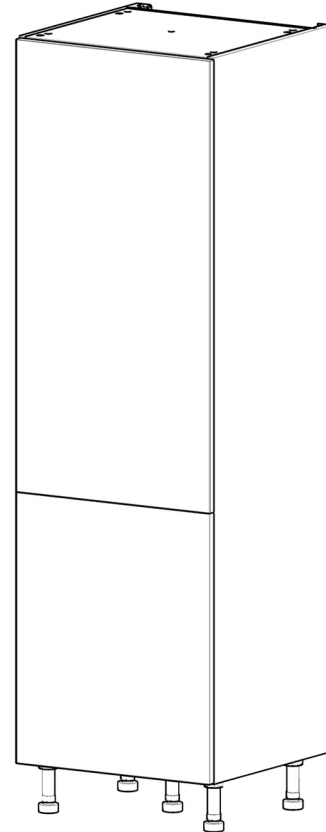

**2070 x 600
70/30**

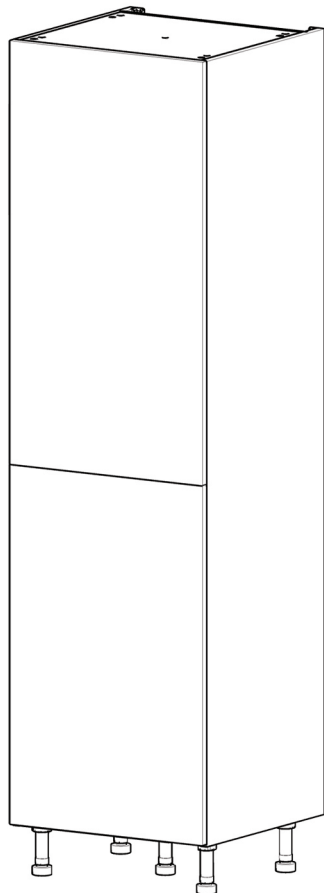

**2250 x 600 Tall
50/50**

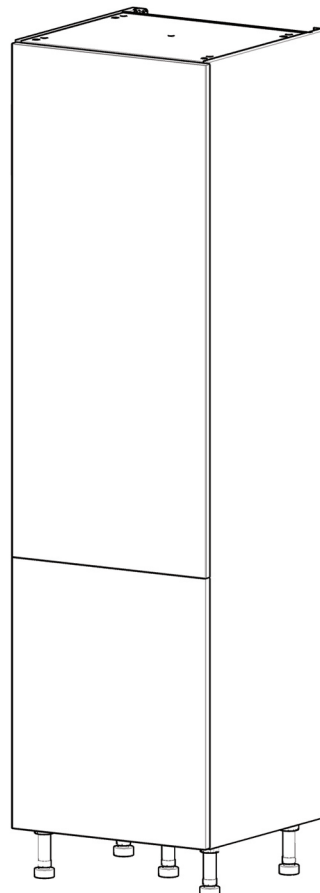

**2250 x 600 Tall
70/30**

wren
KITCHENS

TOWER UNIT

600 2 Door
Fridge/Freezer

Assembly Guide

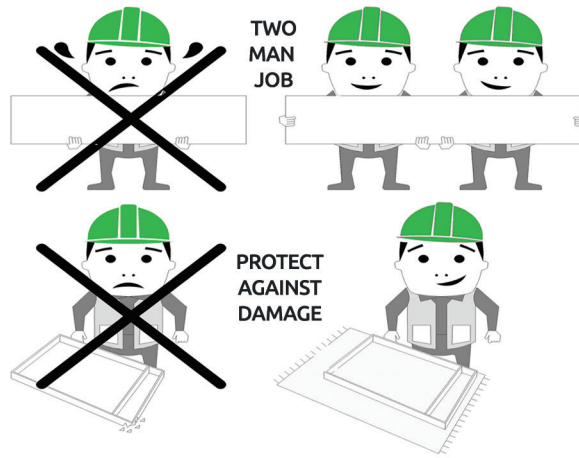

BEFORE YOU START

INSTALLATION
SHOULD BE
PERFORMED BY A
COMPETENT
PERSON ONLY.

THIS PRODUCT COULD
BE DANGEROUS
IF INCORRECTLY
INSTALLED

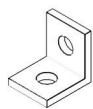
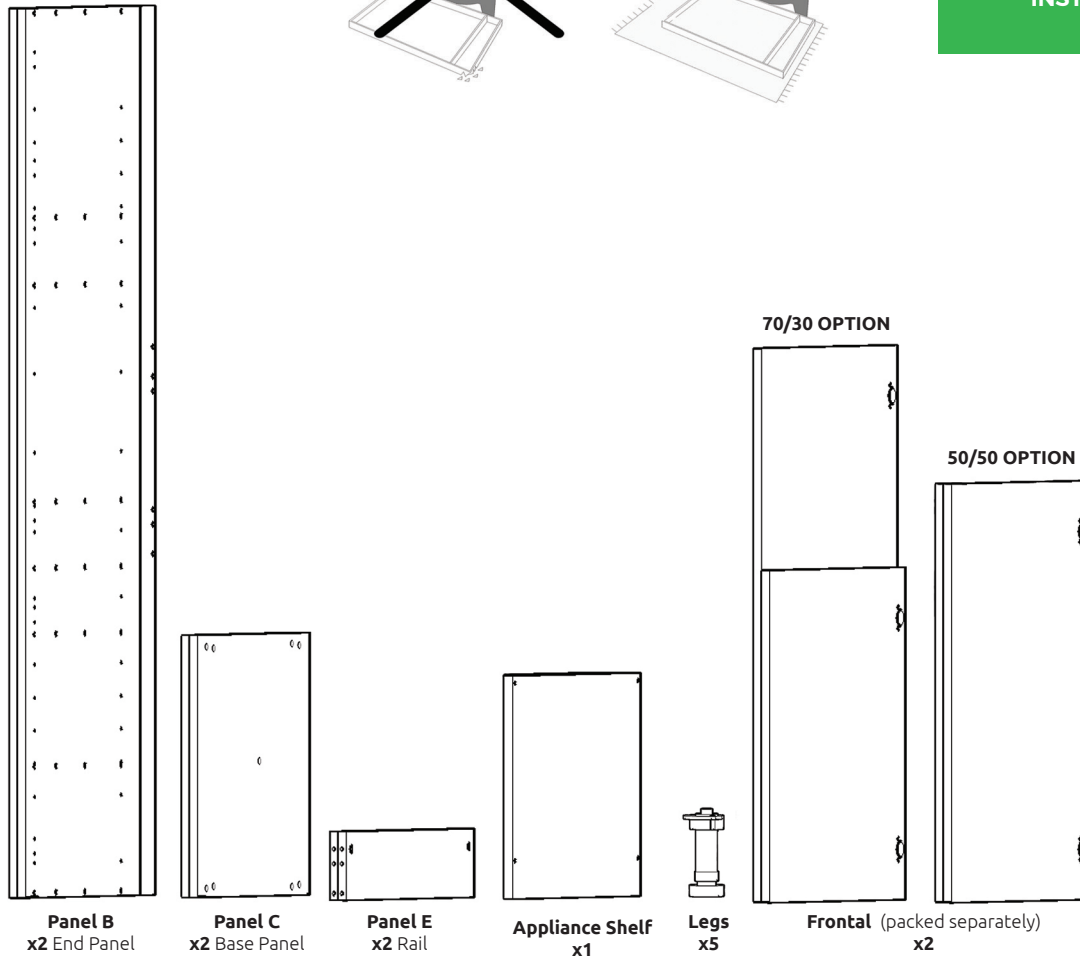

**SML L BRACKET
(W) x4**

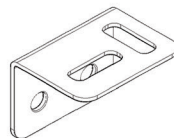

**LGE L BRACKET
x2**

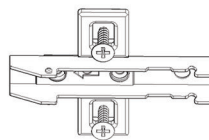

**HINGE MOUNTING PLATE
x4 Inc Screws**

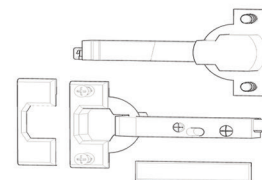

**HINGE
x4 Inc Screws**

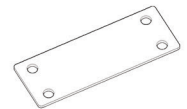

**(M) x2
Fixing Plate**



**(F) x16
Wooden Dowel**



**(G) x12
Cam Dowel
(Expanding)**



**(H) x12
Cam lock**

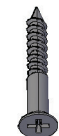

**(K) x10
30mm
Screw**



**(L) x24
15mm
Screw**



**(M) x4
Cover Cap**



**(N) x2
Door Buffer**



**(N) x24
Shelf Peg
Plastic**

REQUIRED TOOLS



NOT to be used
with CAM DOWEL
& CAM LOCK

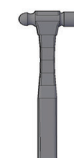

TOWER UNIT

600 2 Door
Fridge/Freezer

Assembly Guide

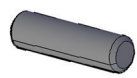

Step 1.

Dowel (F)

Seat dowel (F) into holes in both end panels (B) as shown.

Step 2.

Cam dowel (G)

Seat cam dowel (G) into holes in both end panels (B) as shown.

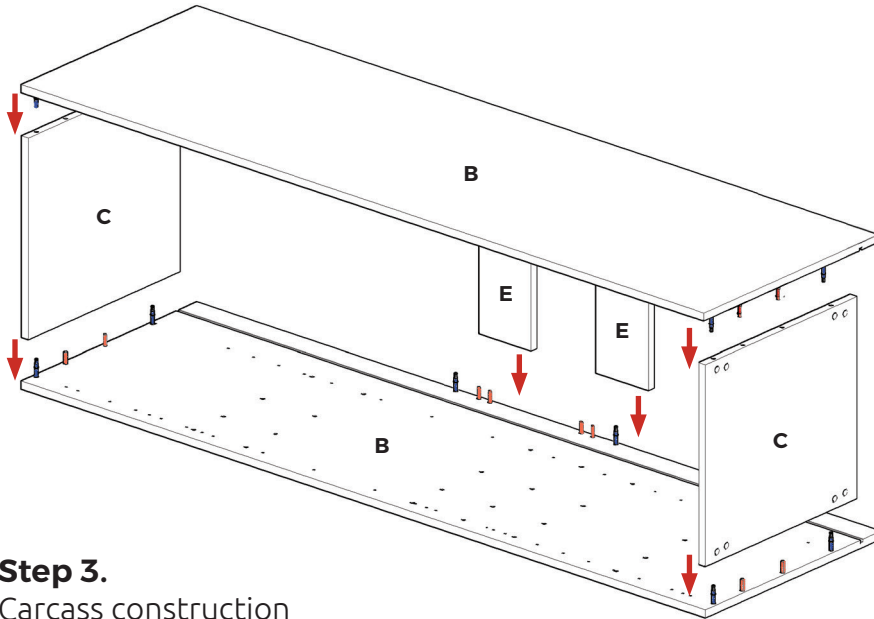
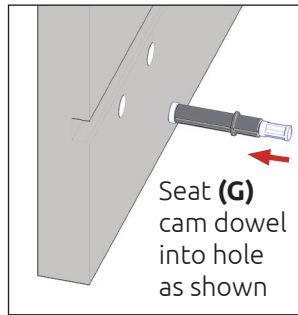

Step 3.

Carcass construction

Attach panels (C) and (E) to panels (B), using cam dowel (G) and also using Dowels (F) (in orange) in positions as shown.

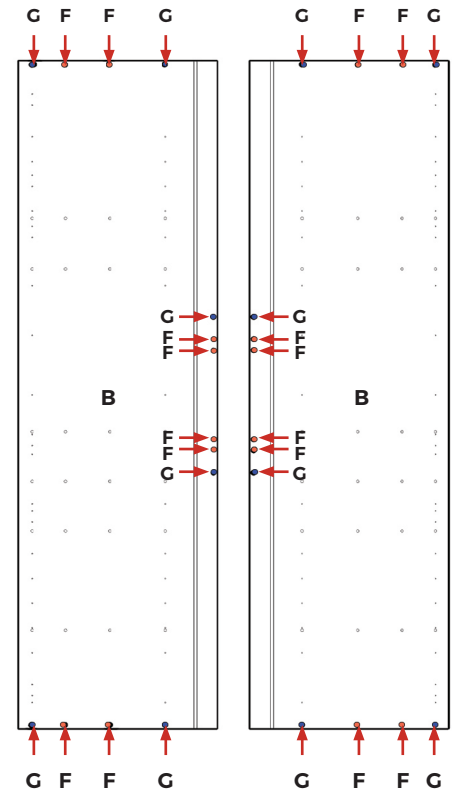

DOWEL (F) & CAM DOWEL (G) LOCATION DETAIL

NB. All **CAM LOCK (H)** are to be positioned facing the outside of the unit carcass, for ease of tightening.

Do **not** use power tools with cam dowel (G) or cam lock (H)

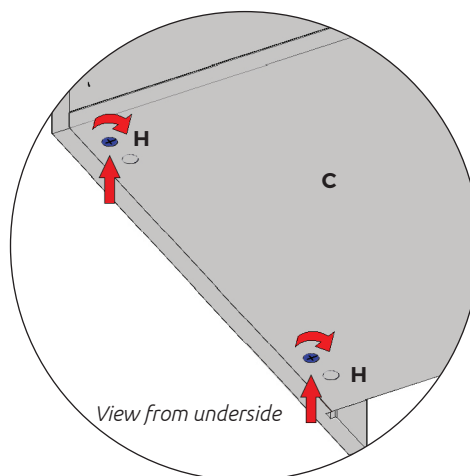
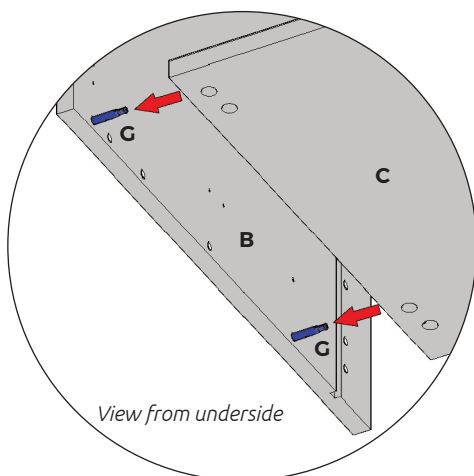

Step 4.

Cam lock (H)

Join panels (C) & (E) to (B). Insert cam lock (H). Do NOT tighten until Step 6.

TOWER UNIT

600 2 Door
Fridge/Freezer

Assembly Guide

Step 5.

Secure each of the legs into place with 2 x 15mm Screws (L).

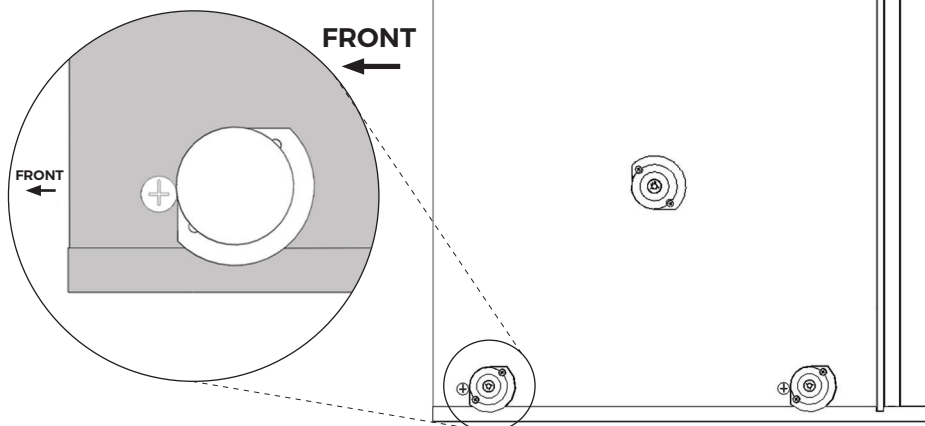

**LEG POSITION
DIAGRAM**

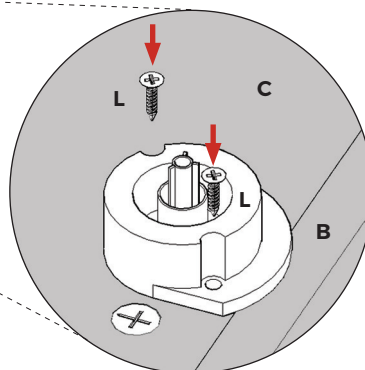
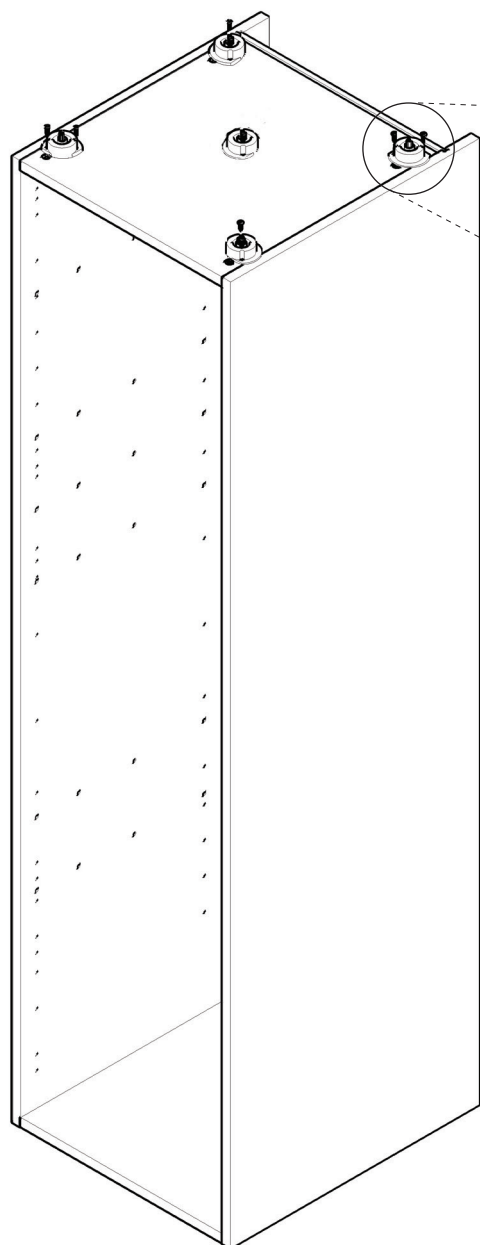

Ensure legs are rotated as shown so that part of it is supporting the end panels (B). Front legs should have the flat edge to the front.

Step 6.

Lightly hit centre peg of leg base with hammer until flush.

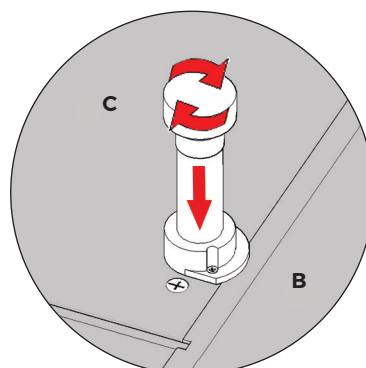
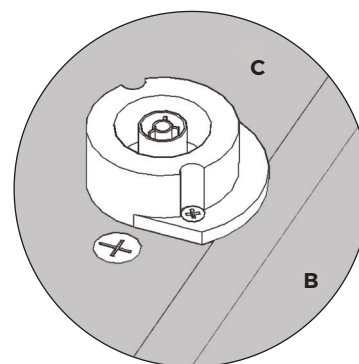
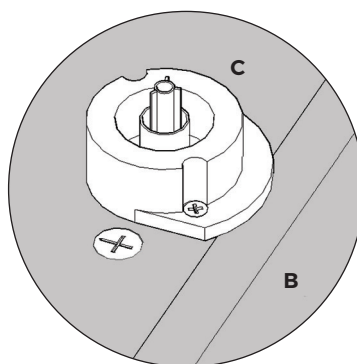

Step 7.

Push leg firmly down into leg base. Adjust legs to 155mm before turning carcass upright. Once in situ level accordingly.

TOWER UNIT

600 2 Door
Fridge/Freezer

2070 Assembly Guide

Hinge mounting plate

Attach hinge plates onto end panels (**B**) in locations shown using 8 x 15mm screws (**L**) hinge side to be mounted in accordance to customer kitchen plan.

N.B. L Bracket

For appliance shelf, secure to panel (**B**) using 4 x brackets (**W**) locate according to customer appliance requirements.

70/30 HINGE POSITION

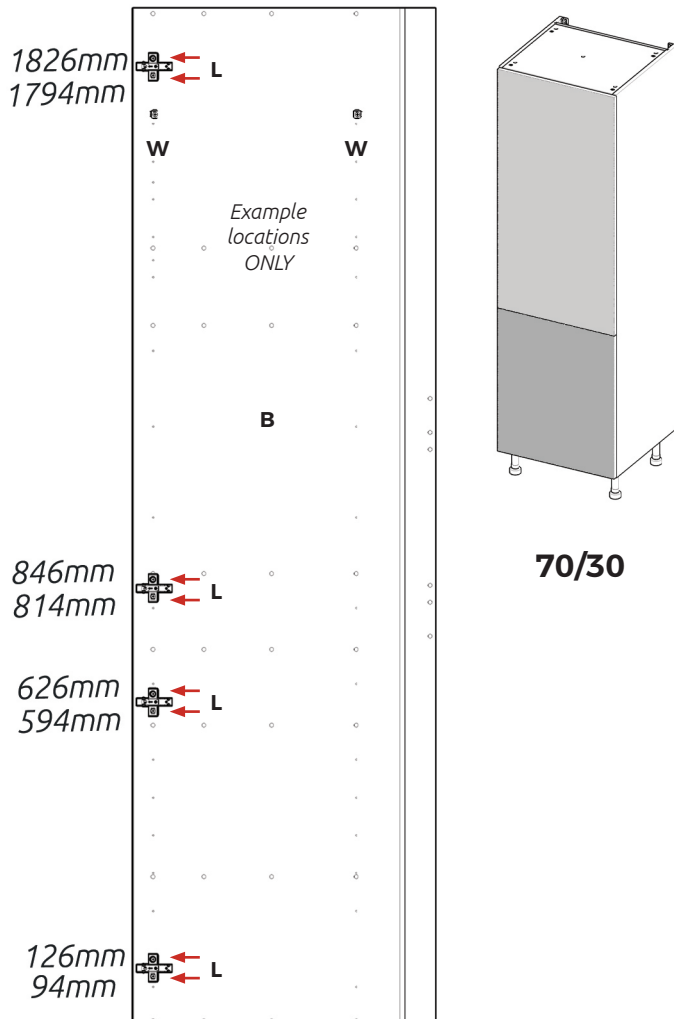

50/50 HINGE POSITION

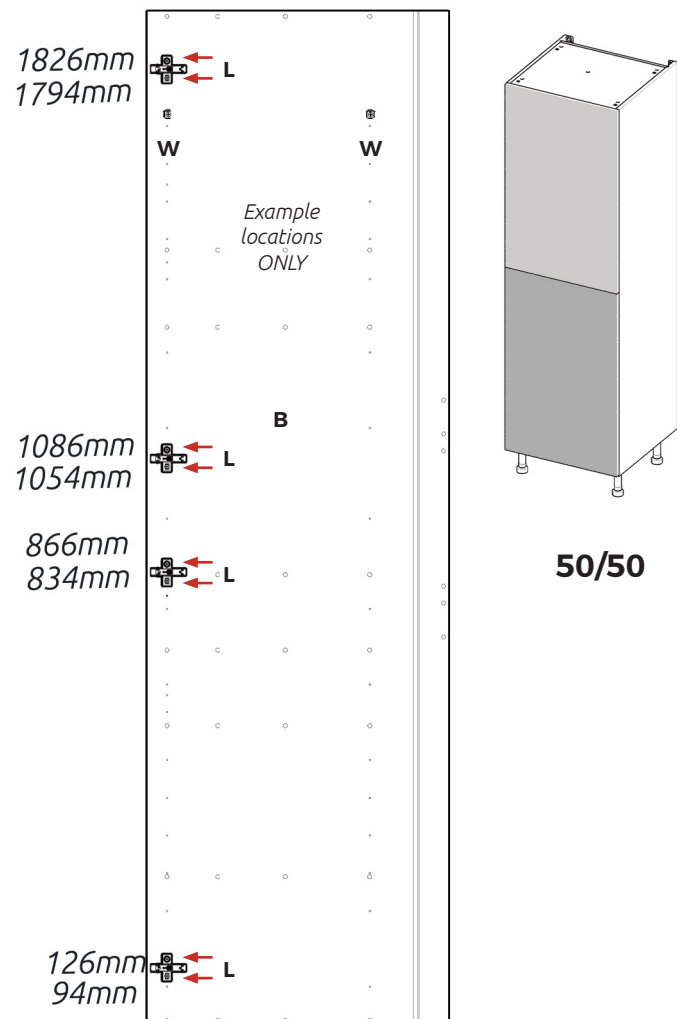

TOWER UNIT

600 2 Door
Fridge/Freezer

2250 Assembly Guide

Hinge mounting plate

Attach hinge plates onto end panels (**B**) in locations shown using 8 x 15mm screws (**L**)

Hinge side to be mounted in accordance to customer kitchen plan.

N.B. L Bracket

For appliance shelf, secure to panel (**B**) using 4 x brackets (**W**) locate according to customer appliance requirements.

70/30 HINGE POSITION

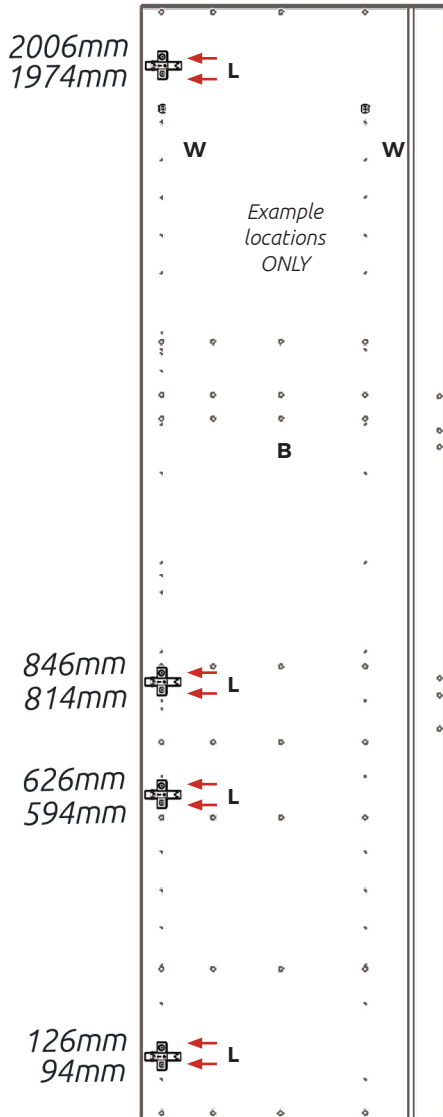

50/50 HINGE POSITION

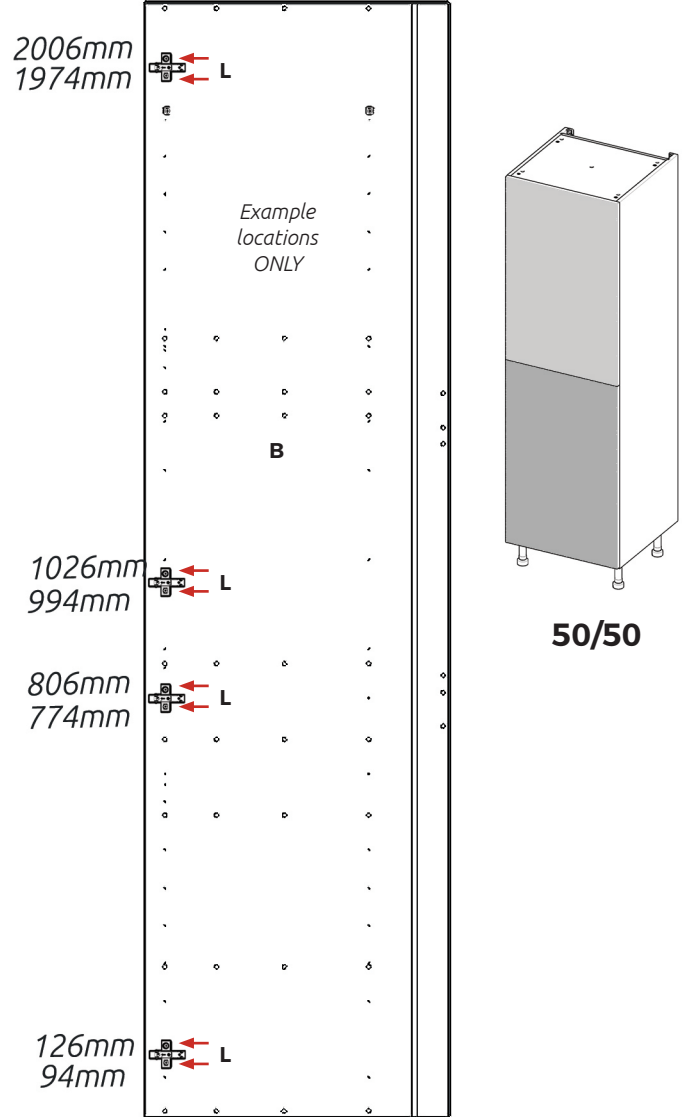

TOWER UNIT

600 2 Door
Fridge/Freezer

Assembly Guide

Secure tower to the wall using the **L brackets** use 2 x 15mm screws (**L**) to secure each of the L brackets to the cabinets at either side. Then screw through into the wall as shown.

Screws for fixing to walls are not provided as these vary depending on your wall material and construction. Ensure appropriate fixings for wall constructions are used.

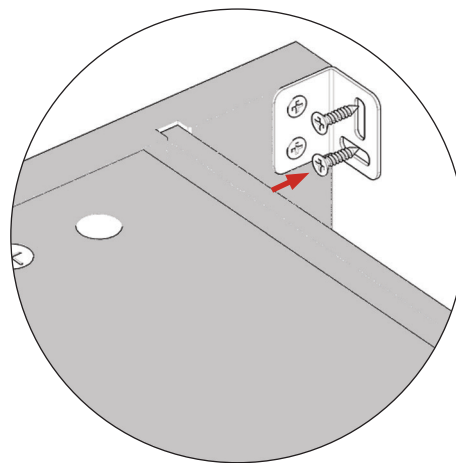
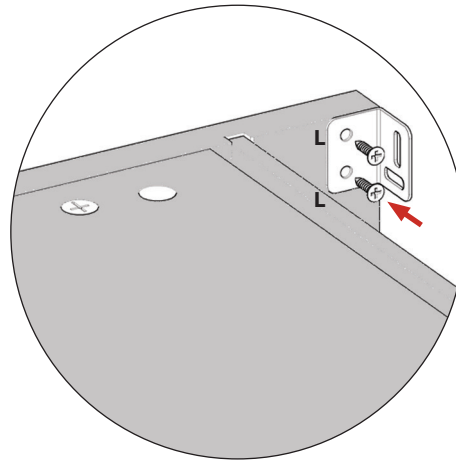

Secure tower to the wall using screws through rail panel (**E**) into the Wall as shown.

Screws for fixing to walls are not provided as these vary depending on your wall material and construction. Ensure appropriate fixings for wall constructions are used.

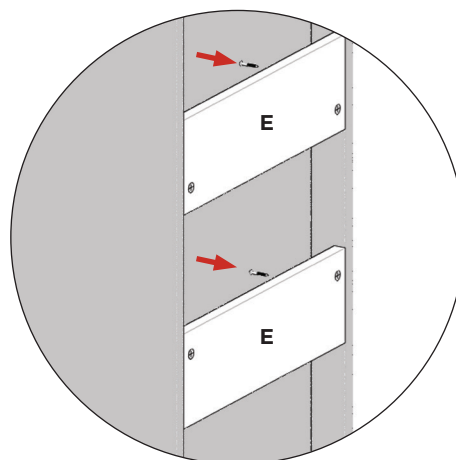

TOWER UNIT

600 2 Door
Fridge/Freezer

Assembly Guide

**FOR TOWER FRONTALS
SEE CUSTOMER SPECIFIC
KITCHEN PLAN**

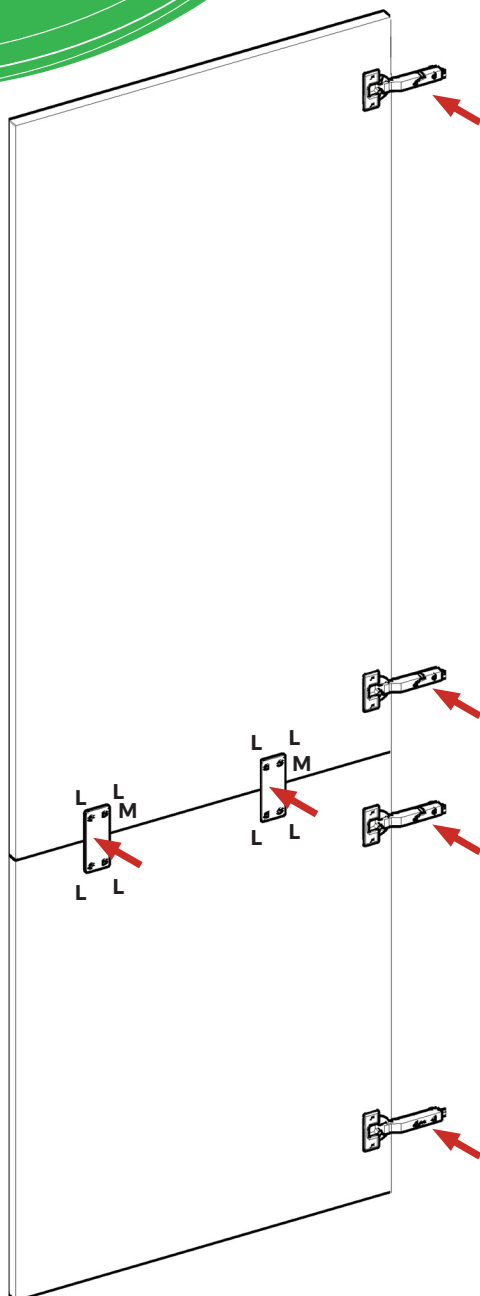
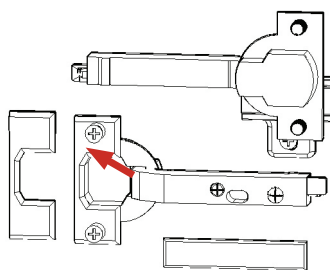

Step 8

Insert hinge in top & bottom frontal holes as shown.

Step 9

Secure hinges by tightening 2 x screws with plastic grommet attached. These are already positioned within the hinges.

Step 10.

Align **doors** to join together using 2 fixing plates (**M**) to the back of both frontals ensure a 3mm gap is maintained between each frontal once fixed together. Screw in place using 4 x 15mm screws (**L**) per fixing plate (**M**).

Step 11.

Attach the door to unit where required. Adjust hinges to suit. See below.

To **attach** door clip hinge onto hinge plate and click to secure.

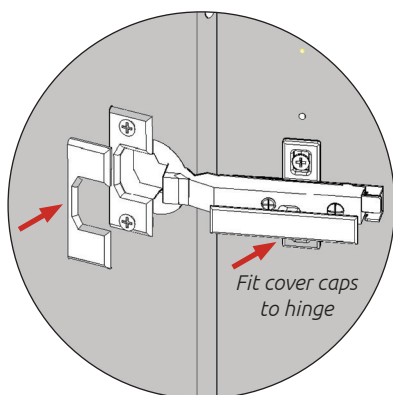
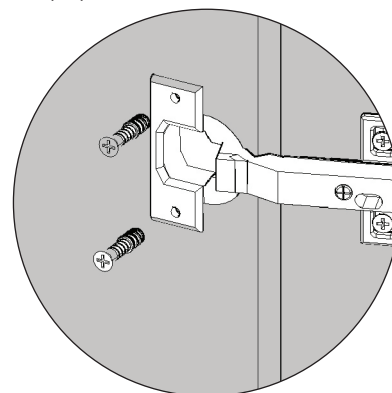

To **adjust** hinge using a screwdriver, tighten or loosen as required at points **1** & **2**.

Point **1** - Left - Right
Point **2** - Side - Side

To **release** door, pull catch as shown, to release hinge from the hinge plate.

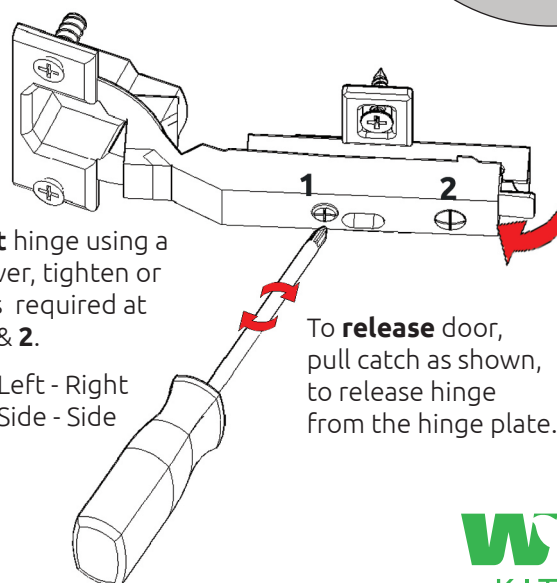

wren
KITCHENS