

Step 1.

Measure units and cut chest top to the required length.

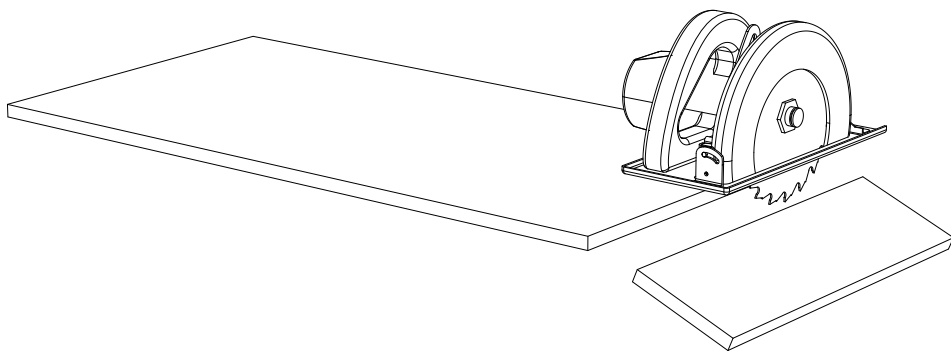

Step 2.

Cut a strip of edging slightly longer than required. Apply worktop edging adhesive to the worktop edge and edging strip, **(adhesive not supplied)**. Ensure the adhesive instructions are followed completely and carefully.

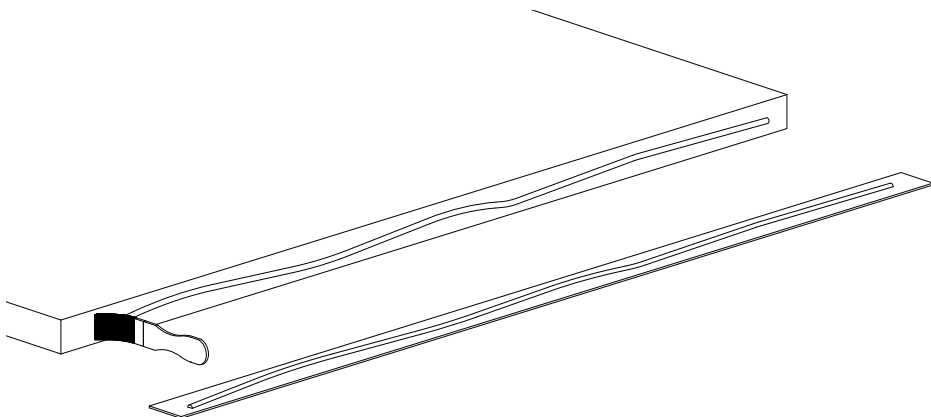

Step 3.

Align the strip along the top edge of the chest top as precisely as possible and press firmly in to place, apply pressure along the length of the strip to smooth. **Follow the adhesive manufactures instructions for supporting the edging strip and drying times.**

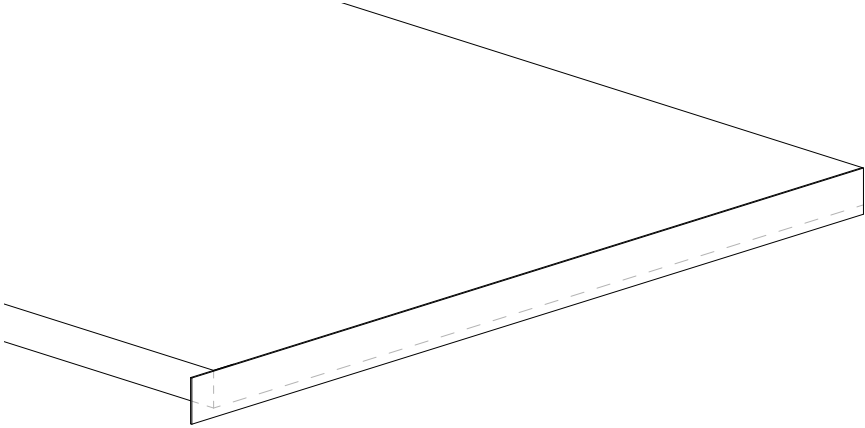

Step 4.

Carefully trim the excess edging away.
BE CAREFUL NOT TO DAMAGE THE CHEST TOP WHEN TRIMMING!

